



US 20160013436A1

(19) **United States**  
(12) **Patent Application Publication**  
**IM et al.**

(10) **Pub. No.: US 2016/0013436 A1**  
(43) **Pub. Date: Jan. 14, 2016**

(54) **ORGANIC LIGHT-EMITTING DIODE DISPLAY DEVICE AND METHOD OF FABRICATING THE SAME**

**Publication Classification**

(71) Applicant: **LG Display Co., Ltd.**, Seoul (KR)

(51) **Int. Cl.**  
*H01L 51/52* (2006.01)  
*H01L 51/56* (2006.01)  
*H01L 51/00* (2006.01)  
*H01L 27/32* (2006.01)

(72) Inventors: **JongHyeok IM**, Busan (KR); **SeJune KIM**, Gyeonggi-do (KR); **JoonSuk LEE**, Seoul (KR); **SoJung LEE**, Gyeonggi-do (KR); **JaeSung LEE**, Seoul (KR)

(52) **U.S. Cl.**  
CPC ..... *H01L 51/5203* (2013.01); *H01L 27/3276* (2013.01); *H01L 51/5237* (2013.01); *H01L 51/5206* (2013.01); *H01L 51/56* (2013.01); *H01L 51/0017* (2013.01)

(73) Assignee: **LG DISPLAY CO., LTD.**, Seoul (KR)

(21) Appl. No.: **14/796,090**

(57) **ABSTRACT**

(22) Filed: **Jul. 10, 2015**

An organic light-emitting diode (OLED) display device and a method of fabricating the same can reduce resistance of a cathode by forming an auxiliary electrode. Also, such OLED display device and method can prevent damage on a pad electrode due to an etchant during patterning of an anode by applying a protective structure to the pad electrode of a pad area and by including the pad electrode exposed from a plurality of pad electrode layers.

(30) **Foreign Application Priority Data**

Jul. 11, 2014 (KR) ..... 10-2014-0087665  
Jul. 11, 2014 (KR) ..... 10-2014-0087751  
Jul. 9, 2015 (KR) ..... 10-2015-0097544

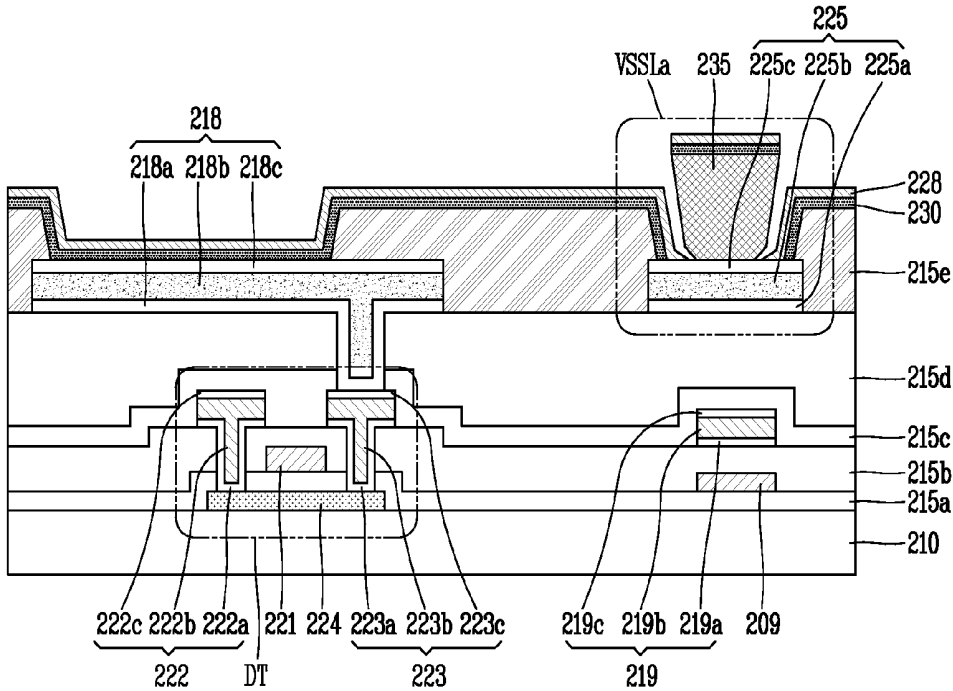

FIG. 1

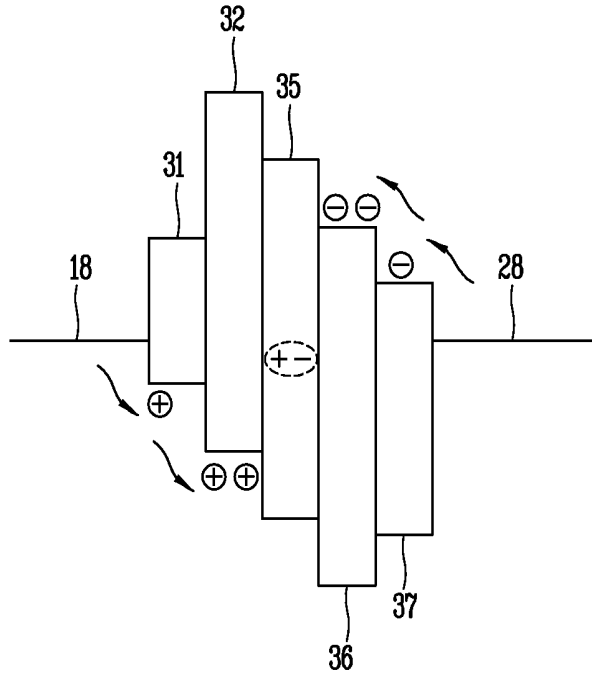

FIG. 2

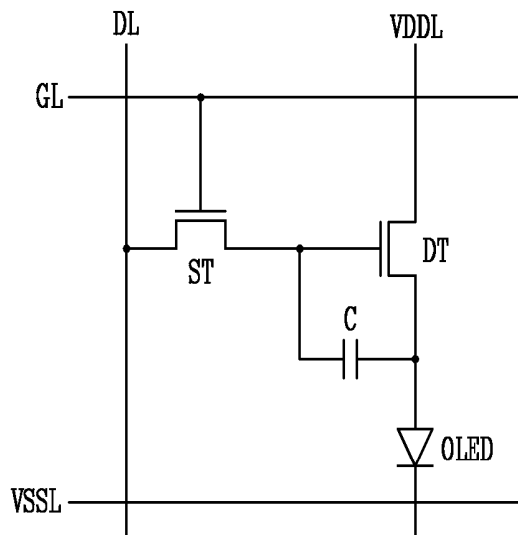

FIG. 3

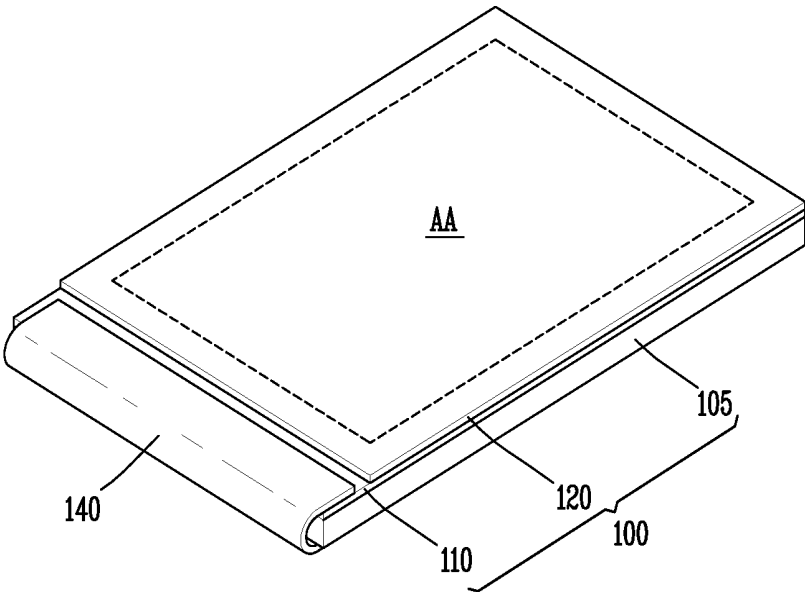

FIG. 4A

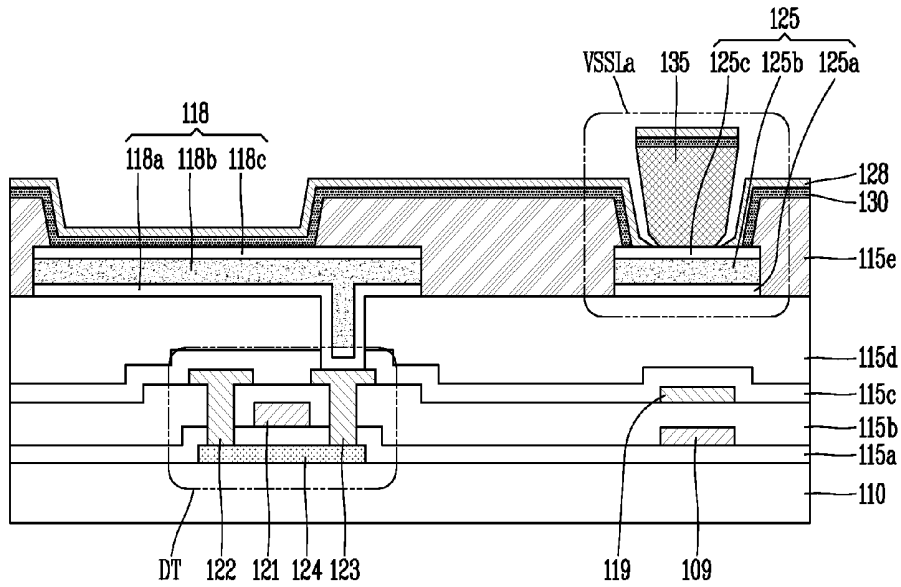

FIG. 4B

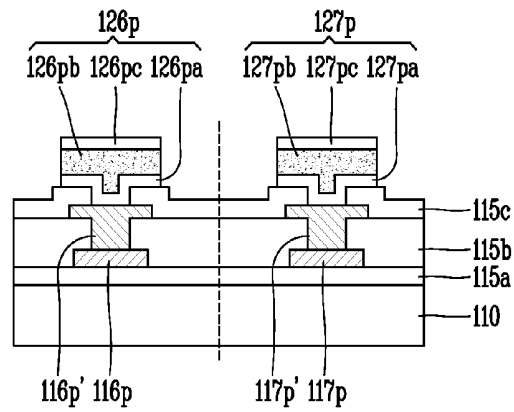

FIG. 5A

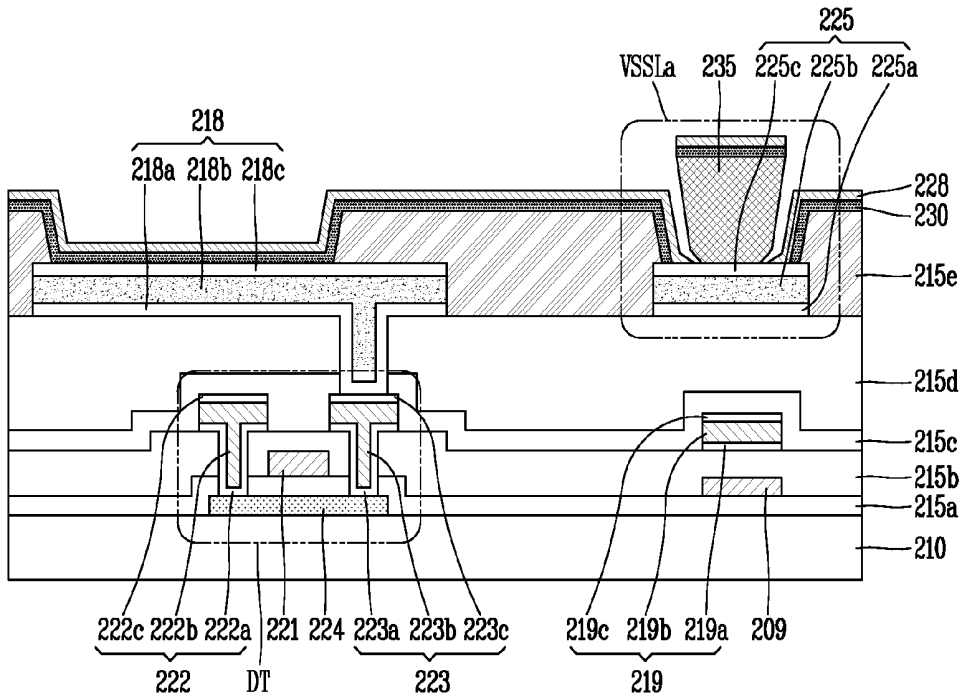

FIG. 5B

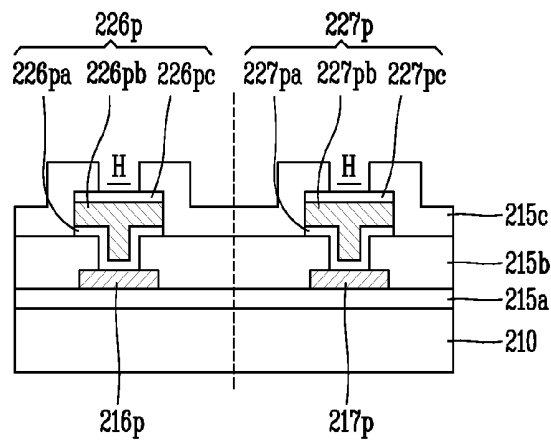

FIG. 6A



FIG. 6B

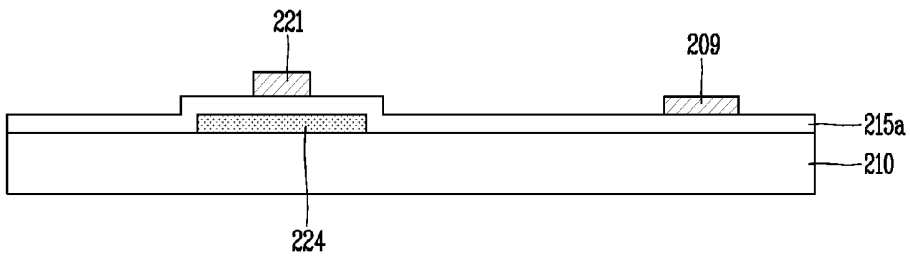

FIG. 6C

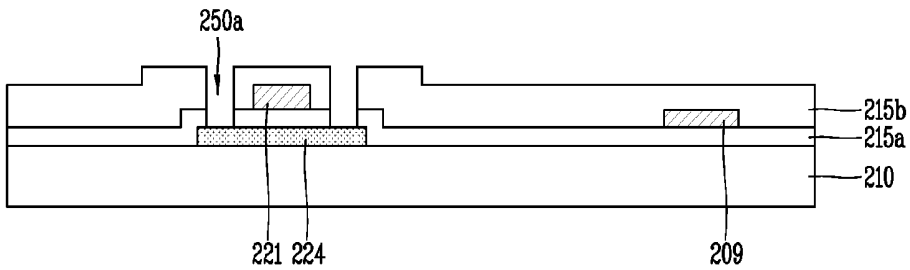

FIG. 6D

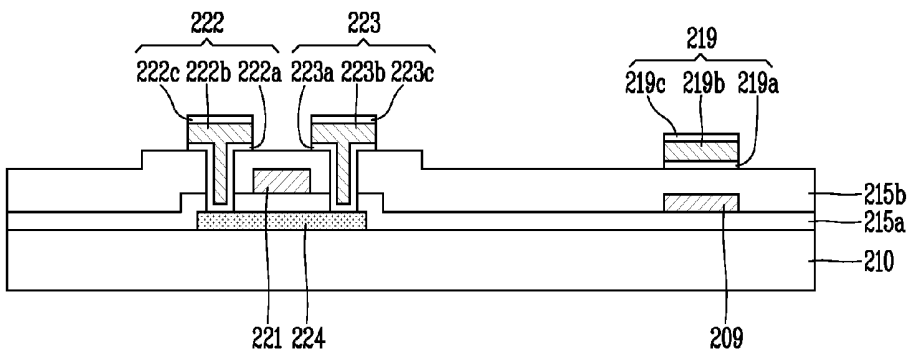

FIG. 6E

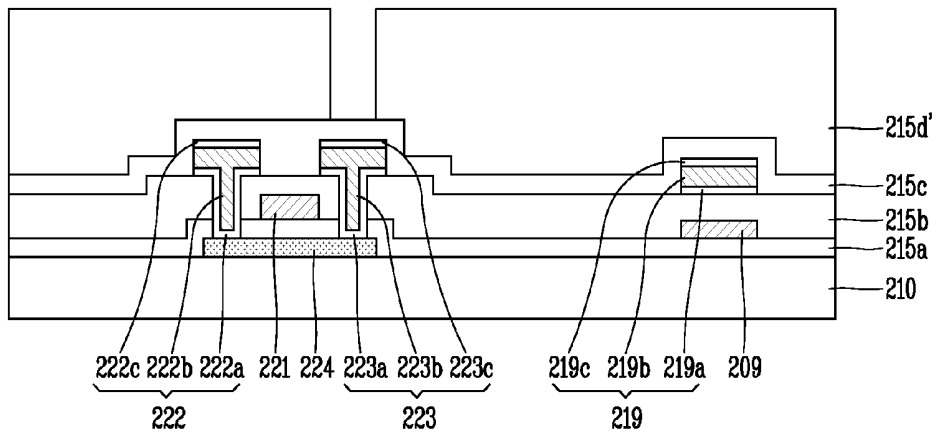

FIG. 6F

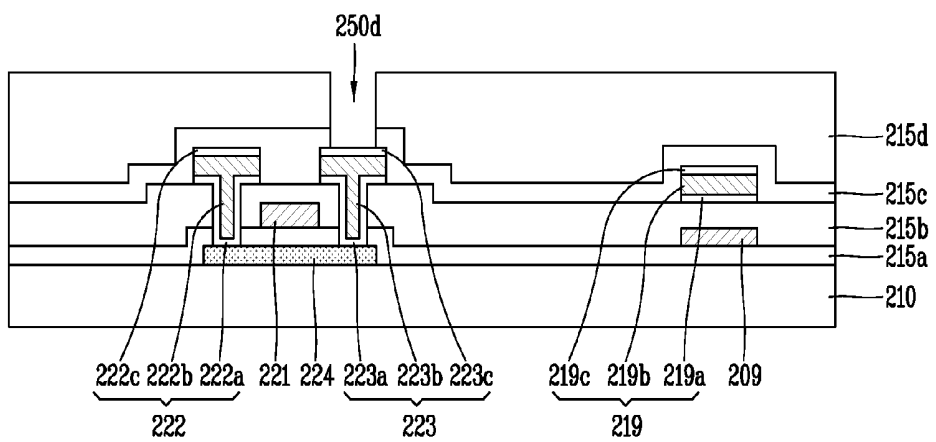

FIG. 6G

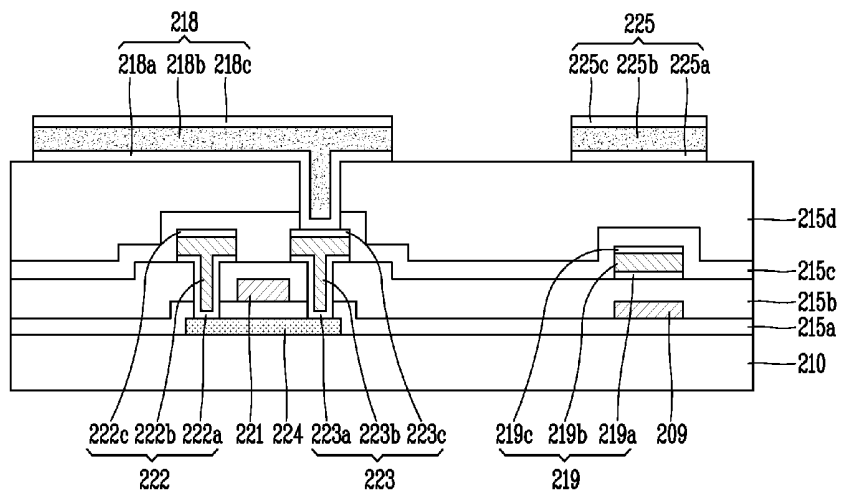

FIG. 6H

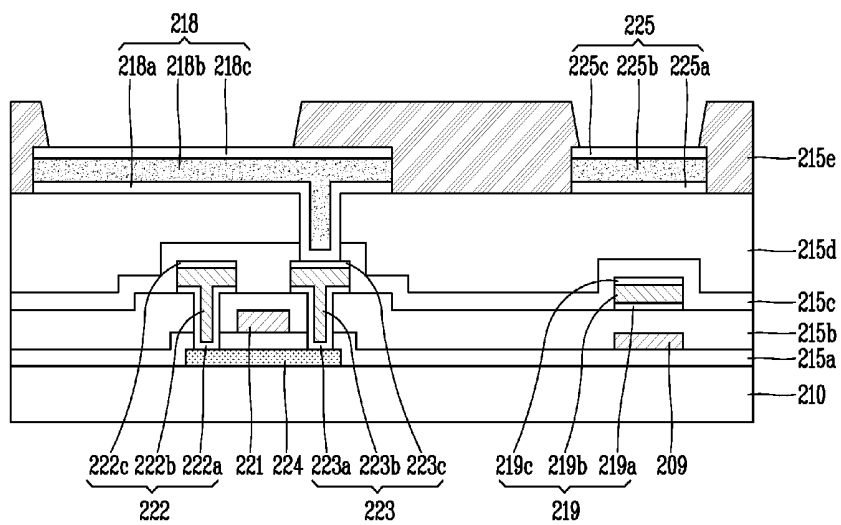

FIG. 6I

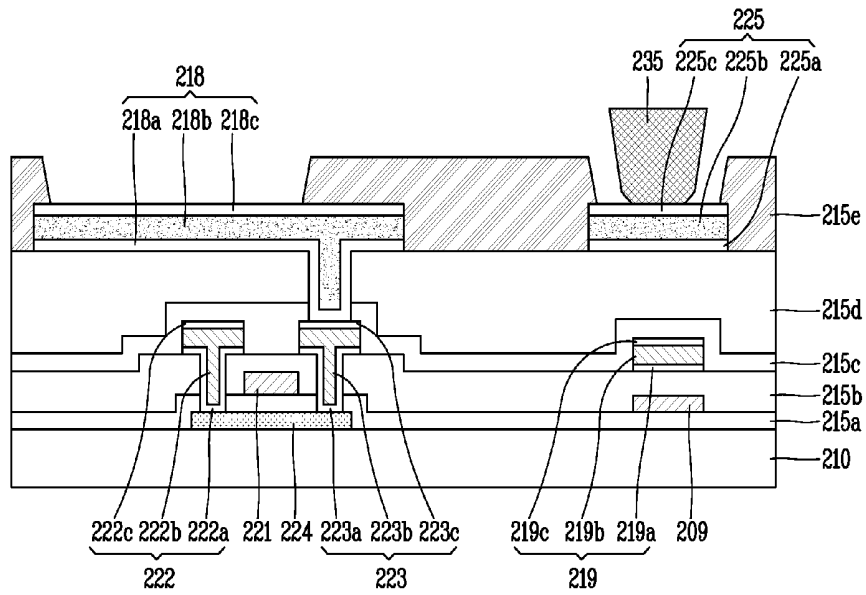

FIG. 6J

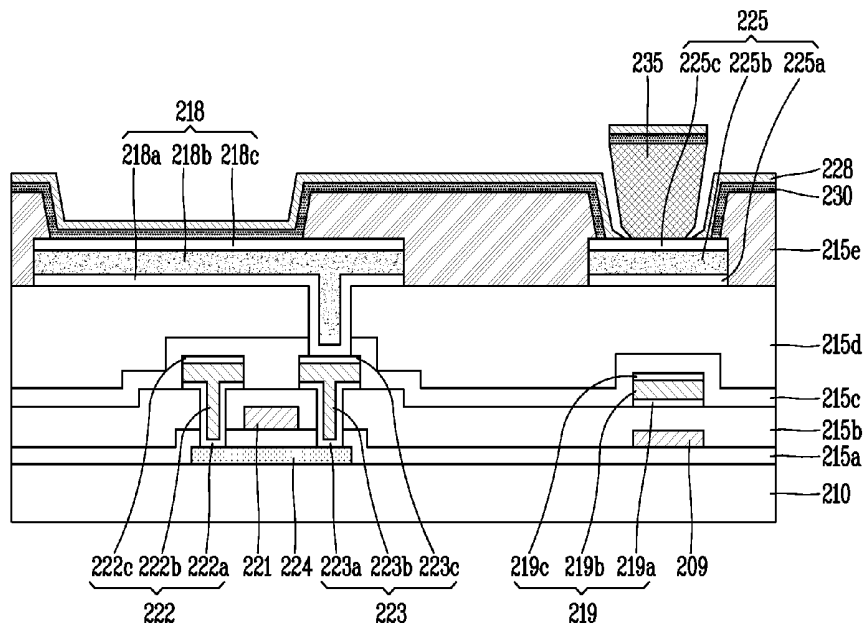

FIG. 7A

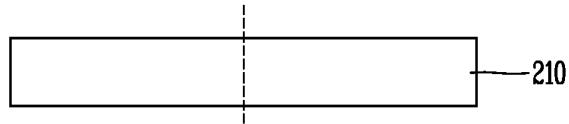

FIG. 7B

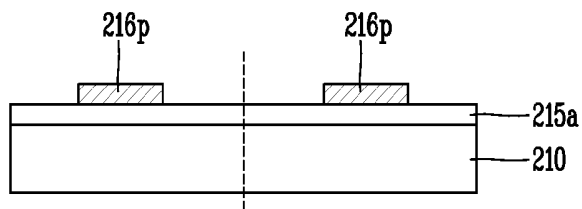

FIG. 7C

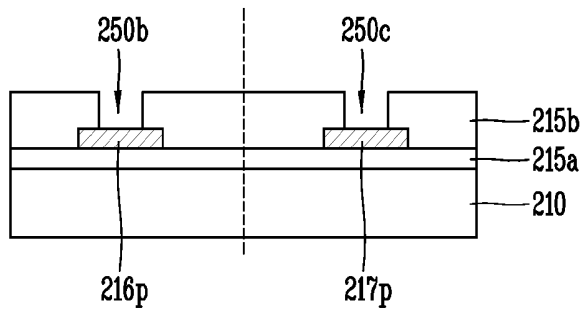

FIG. 7D

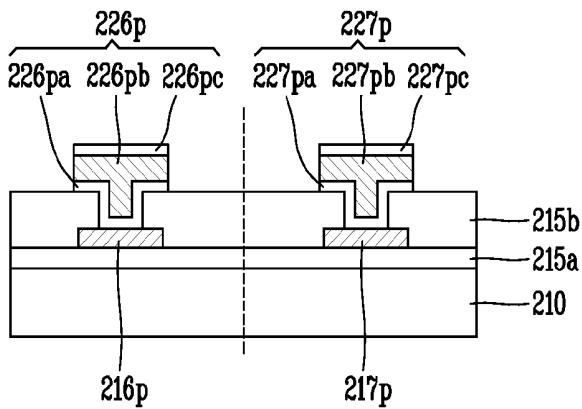

FIG. 7E

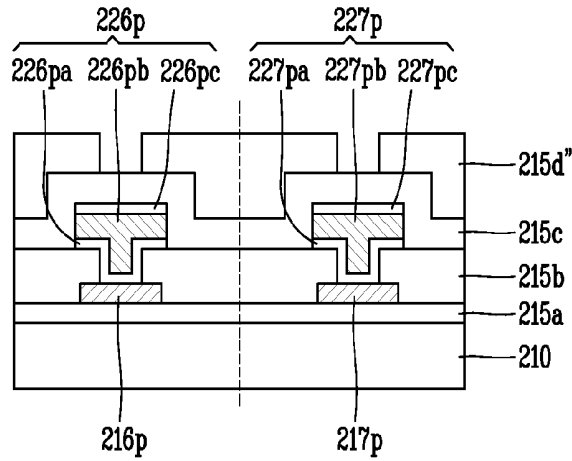

FIG. 7F

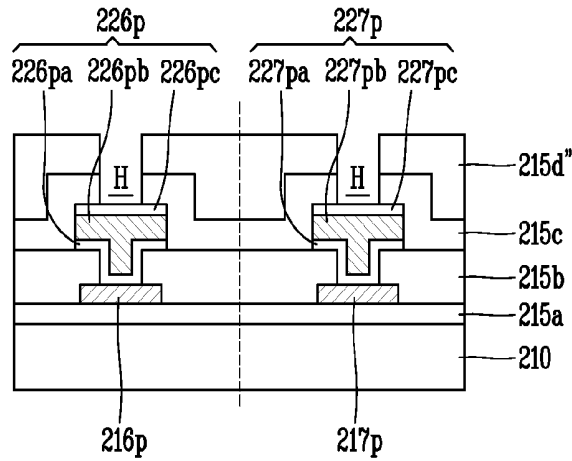

FIG. 7G

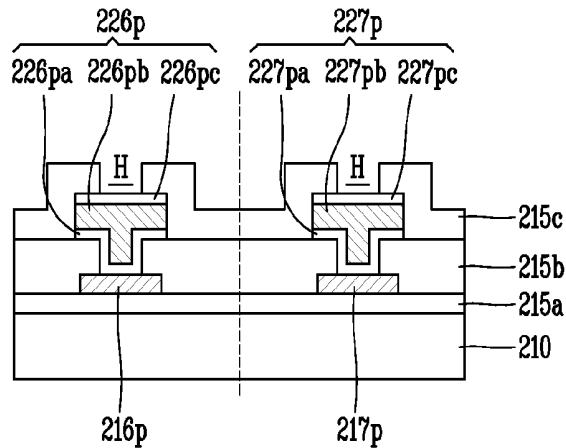

FIG. 8A

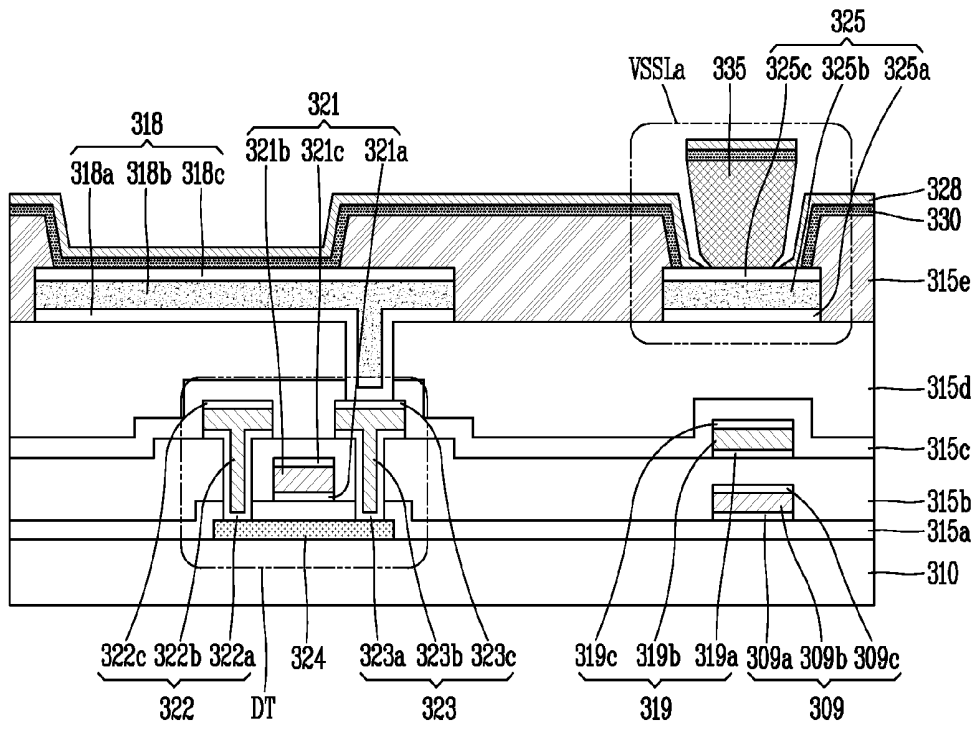

FIG. 8B

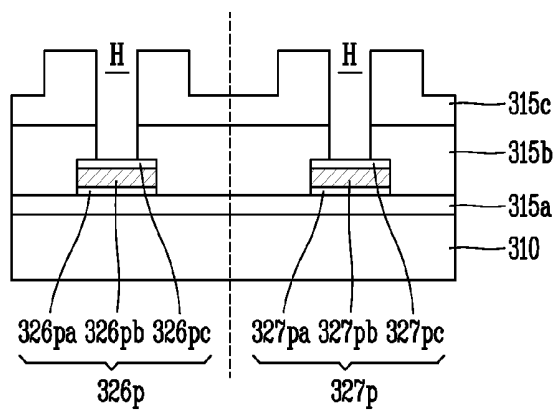

FIG. 9A

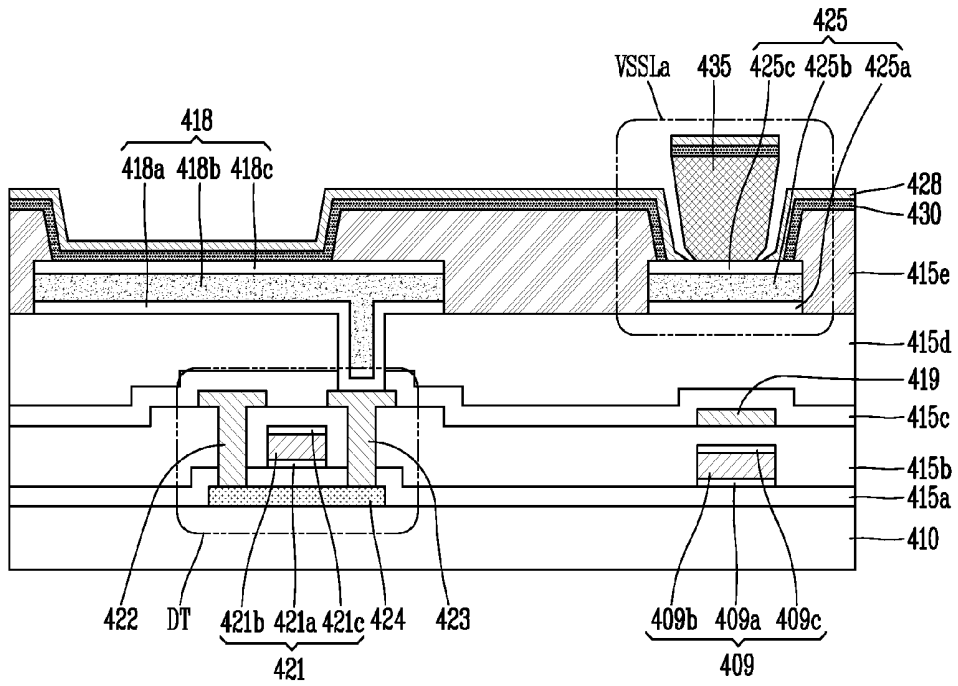

FIG. 9B

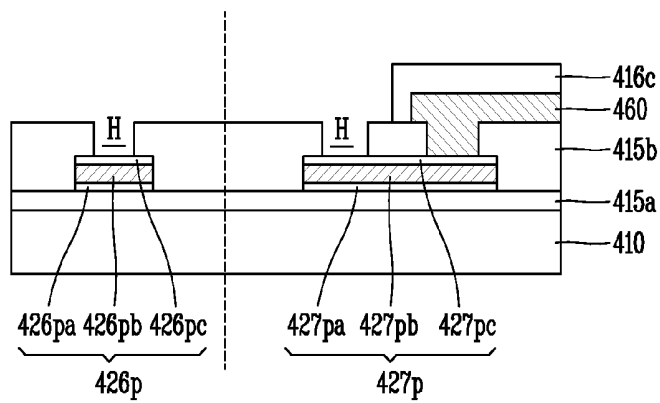

FIG. 10A

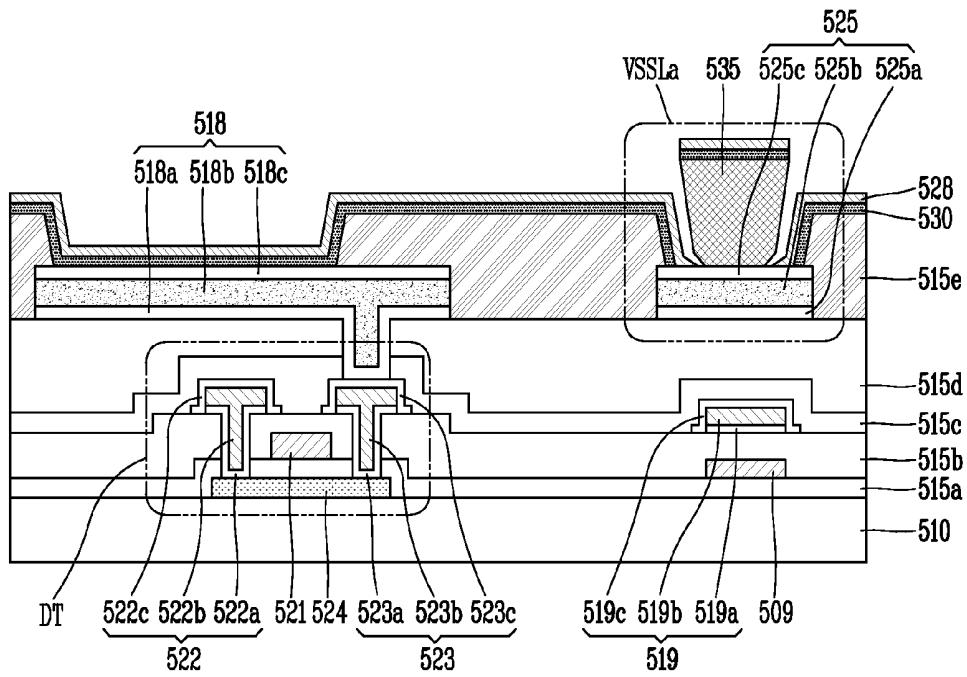

FIG. 10B

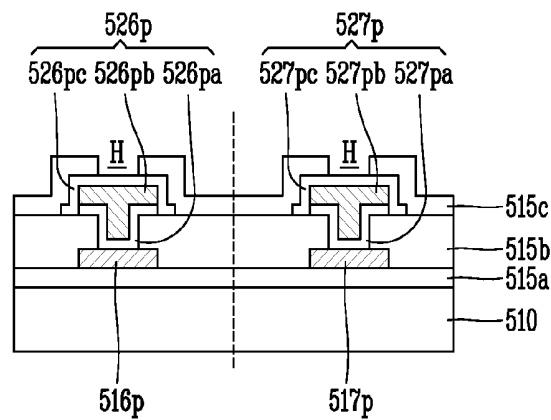

FIG. 11A



FIG. 11B

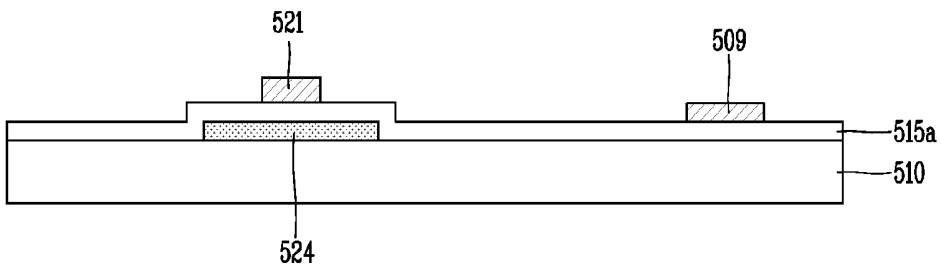

FIG. 11C

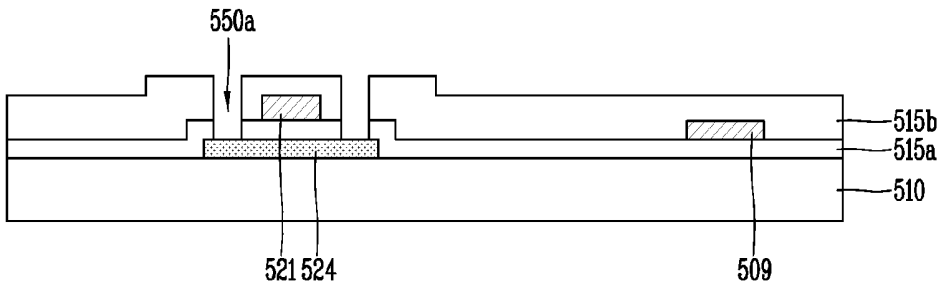

FIG. 11D

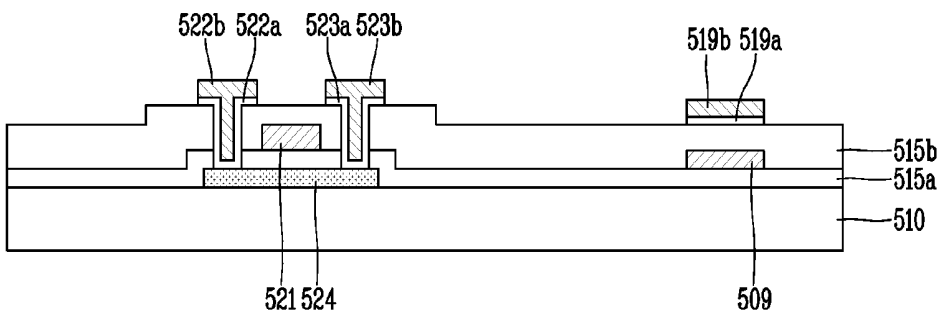

FIG. 11E

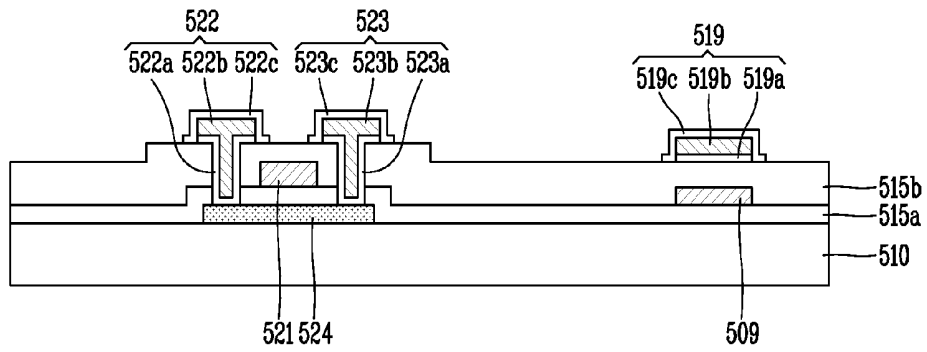

FIG. 11F

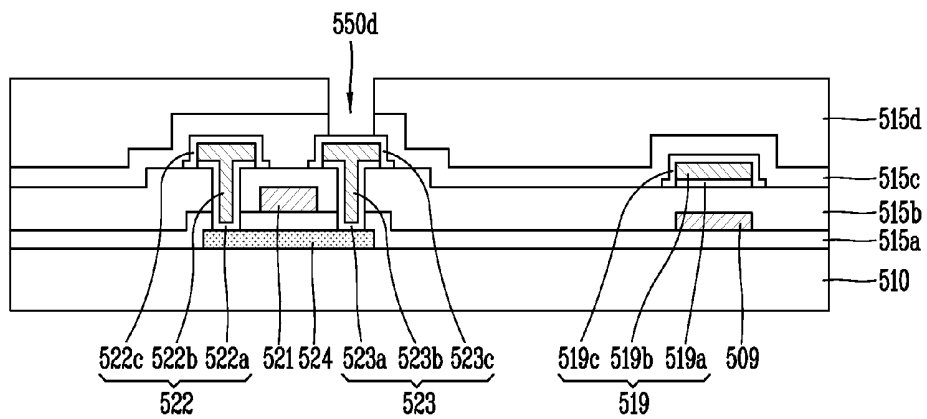

FIG. 11G

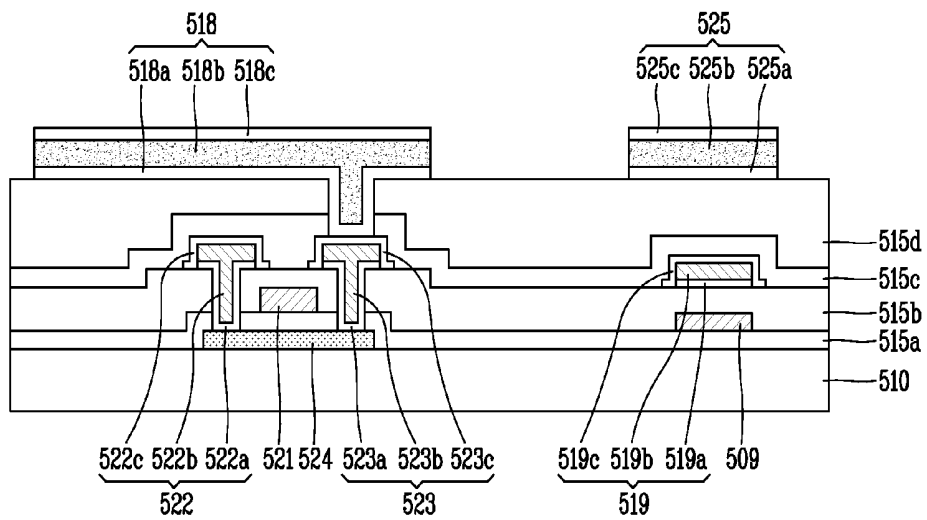

FIG. 11H

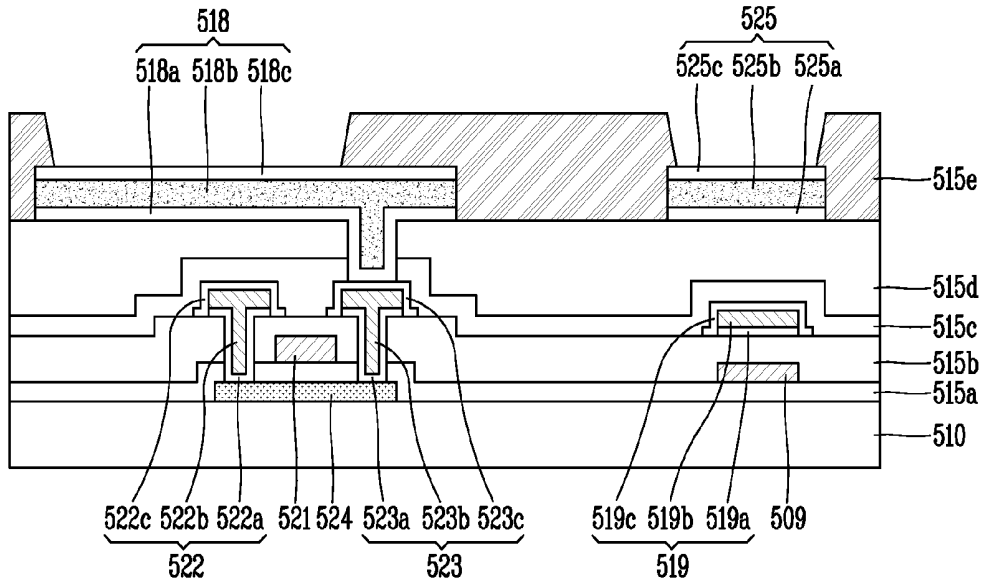

FIG. 11I

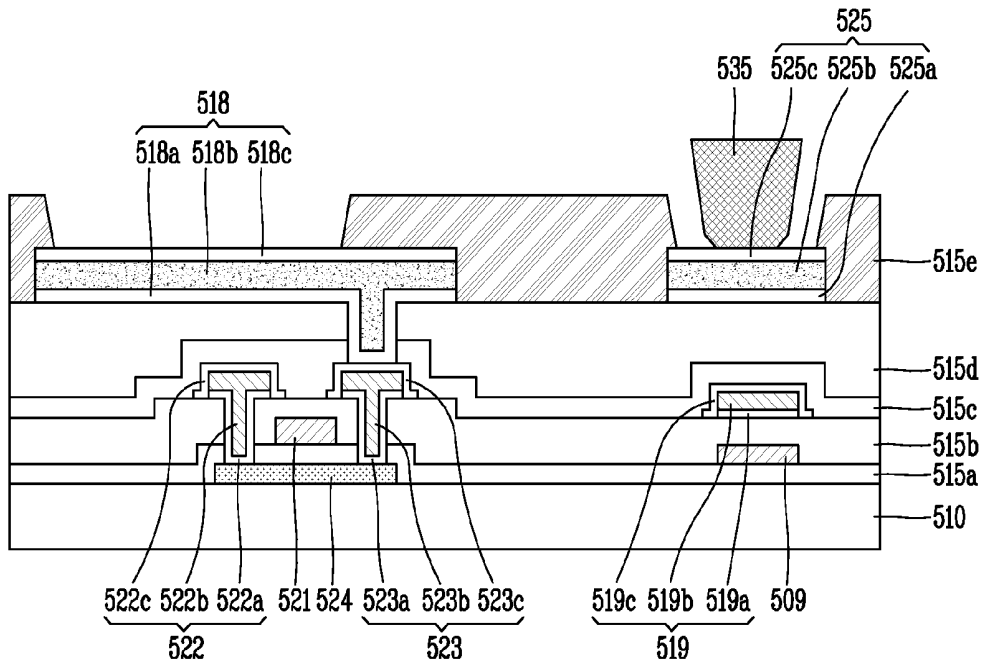

FIG. 11J

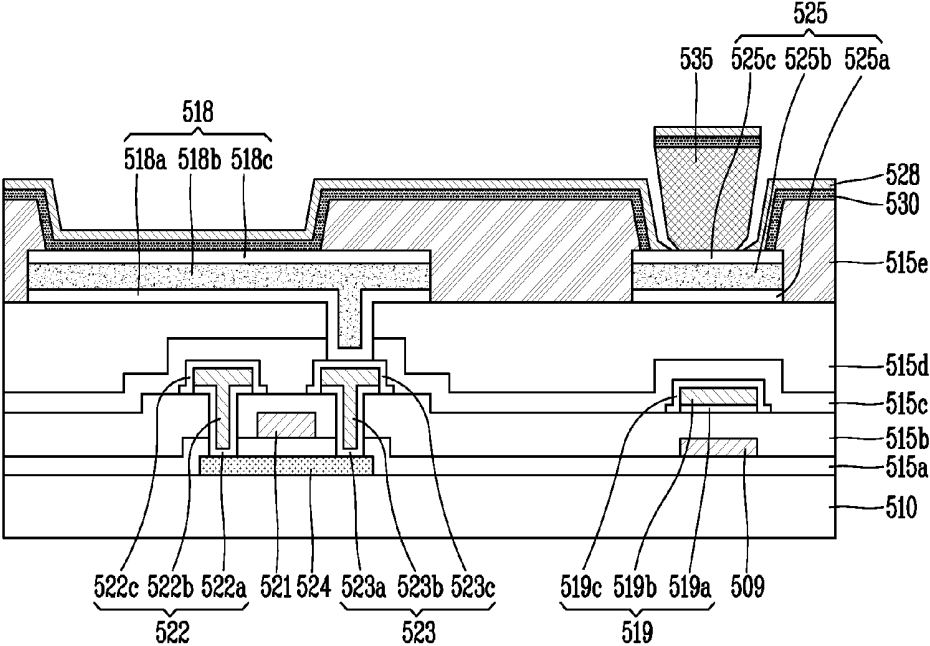

FIG. 12A

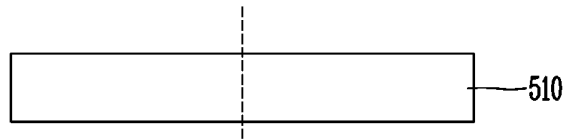

FIG. 12B

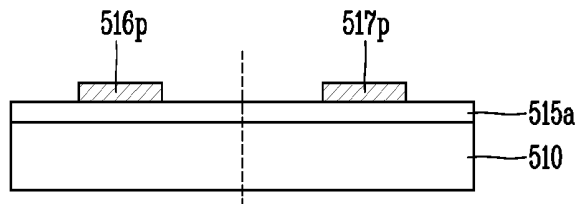

FIG. 12C

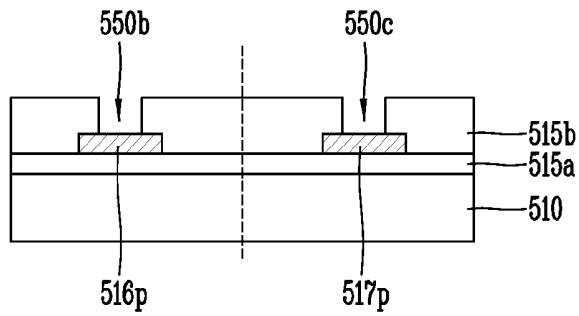

FIG. 12D

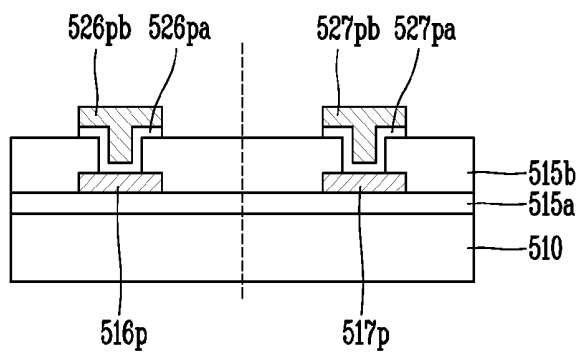

FIG. 12E

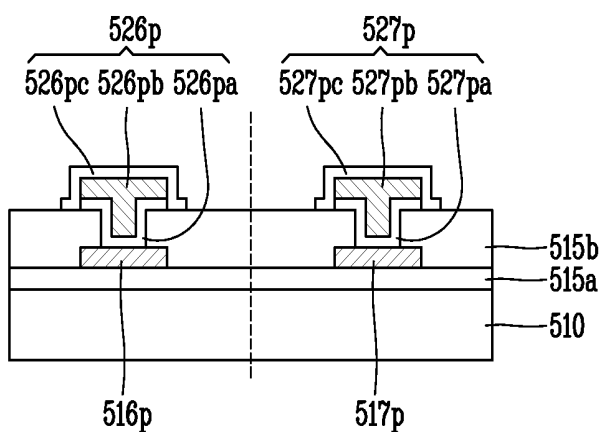
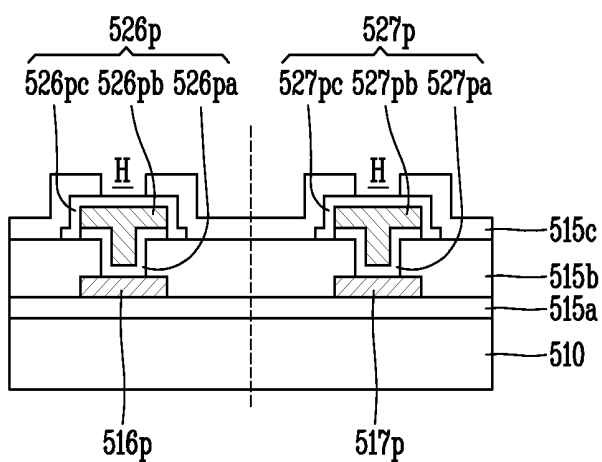

FIG. 12F



**ORGANIC LIGHT-EMITTING DIODE  
DISPLAY DEVICE AND METHOD OF  
FABRICATING THE SAME**

CROSS-REFERENCE TO RELATED  
APPLICATION

[0001] Pursuant to 35 U.S.C. §119(a), this application claims the benefit of earlier filing date and right of priority to Korean Application Nos. 10-2014-0087665, filed on Jul. 11, 2014, 10-2014-0087751 filed on Jul. 11, 2014, and 10-2015-0097544 filed on Jul. 9, 2015, the contents of which are incorporated by reference herein in their entireties.

BACKGROUND OF THE DISCLOSURE

[0002] 1. Field of the Disclosure

[0003] This specification relates to an organic light-emitting diode (OLED) display device and a method of fabricating the same, and more particularly, a top emission type OLED display device and a method of fabricating the same.

[0004] 2. Background of the Disclosure

[0005] As the interest in information display and demand on the use of portable information media increase, research efforts and commercialization are focusing mainly on display devices such as flat panel displays (FPDs) which are light in weight and thin in thickness.

[0006] Specifically, among such displays, liquid crystal display (LCD) devices have seen widespread use in view of its light weight and low power consumption.

[0007] As another display device, an organic light-emitting diode (OLED) display device emits light by itself and thus exhibits more excellent viewing angle and contrast ratio than the LCD device. Also, the OLED display device does not need a backlight and thus is advantageous in reduced weight, thickness and power consumption. The OLED display device is also current driven based upon a direct-current (DC) low voltage and exhibits a fast response speed.

[0008] Hereinafter, the basic structure and operation characteristics of an OLED display device will be described with reference to the drawings.

[0009] FIG. 1 is a diagram illustrating a light-emitting principle of a typical OLED.

[0010] An OLED display device typically includes an OLED having a structure as illustrated in FIG. 1.

[0011] Referring to FIG. 1, the OLED includes an anode **18** as a pixel electrode, a cathode **28** as a common electrode, and an organic compound layer(s) **31**, **32**, **35**, **36** and **37** formed between the anode **18** and the cathode **28**.

[0012] Here, the organic compound layer(s) **31**, **32**, **35**, **36** and **37** includes a hole injection layer **31**, a hole transport layer **32**, an emission layer **35**, an electron transport layer **36**, and an electron injection layer **37**. All or some of these layers may be separate or some may be combined together such that one layer is implemented with multiple functions.

[0013] With the configuration of the OLED, when positive (+) and negative (-) driving voltages are applied to the anode **18** and the cathode **28**, respectively, holes passed through the hole transport layer **32** and electrons passed through the electron transport layer **36** are moved to the emission layer **35** to form excitons. When the excitons transit from an excited state into a base state, namely, a stable state, light with a predetermined wavelength is emitted.

[0014] In the OLED display device, sub pixels each having the OLED with the aforementioned structure are arranged in

the matrix configuration. The sub pixels are selectively controlled by a data voltage and a scan voltage, to display various colors that collectively form an image.

[0015] Here, the OLED display device can be categorized into a passive matrix type and an active matrix type using thin film transistors (TFT) as switching elements. Of those types, in the active matrix type OLED display device, the TFT as an active element is selectively turned on to select a sub pixel and light emission of the sub pixel occurs due to voltage charged in a storage capacitor.

[0016] The OLED display device may also be categorized according to a light-emitting direction into a top emission type, a bottom emission type and a dual emission type.

[0017] The top emission type OLED display device is configured to emit light in a direction away from a substrate on which the sub pixels are arranged. The top emission type OLED display device is advantageous in that aperture ratio is greater than that of a bottom emission type in which light is emitted toward and through the substrate with the sub pixels arranged thereon.

[0018] The top emission type OLED display device includes an anode provided below an organic compound layer and a cathode provided above the organic compound layer through which light is transmitted.

[0019] Here, the cathode should be formed thin (~100 Å) enough to be implemented as a semi-transparent layer with a low work function. However, doing so causes the cathode to have high resistance.

[0020] The thusly-configured top emission type OLED display device results in formation of a voltage drop (IR drop) by high specific resistance of the cathode. Accordingly, undesirably different levels of voltages are applied to sub pixels, respectively. This brings about non-uniform luminance or image quality. Specifically, as a size of a panel increases more, the voltage drop (IR drop) problem may become aggravated.

[0021] The OLED display device can be divided into a display area and a pad area located outside the display area.

[0022] The TFT and the OLED are formed in the display area.

[0023] A pad electrode is formed in the pad area to apply a signal voltage from an external power source to the TFT and the OLED.

[0024] In this case, pad electrodes formed in the pad area may suffer from corrosion due to moisture and oxygen. In addition, the corrosion may be caused by a specific etchant with respect to the material constituting the pad electrode. When the pad electrode corrodes, the transmission of signals is problematic, and thus the overall device reliability decreases.

SUMMARY OF THE DISCLOSURE

[0025] Accordingly, the present invention is directed to a n organic light-emitting diode (OLED) display device and method of manufacturing the same that substantially obviate one or more of the problems due to limitations and disadvantages of the related art.

[0026] An object of the present invention is to provide an organic light-emitting diode (OLED) display device, capable of preventing (or minimizing) corrosion on a pad electrode caused by moisture and oxygen and preventing (or minimizing) damage on the pad electrode caused by an etchant during patterning of an anode, and a method of fabricating the same.

[0027] Another object of the present invention is to provide an OLED display device, capable of simplifying the process required to form a plurality of the pad electrode layers, and a method of fabricating the same.

[0028] Additional features and advantages of the invention will be set forth in the description which follows, and in part will be apparent from the description, or may be learned by practice of the invention. The objectives and other advantages of the invention will be realized and attained by the structure particularly pointed out in the written description and claims hereof as well as the appended drawings.

[0029] To achieve these and other advantages and in accordance with the purpose of this specification, as embodied and broadly described herein, an organic light-emitting diode (OLED) display device comprises a thin film transistor on a display area of a substrate; an OLED connected to the thin film transistor; and a plurality of pad electrodes comprising at least a first pad electrode layer, a second pad electrode layer and a third pad electrode layer on a pad area of the substrate, wherein the first pad electrode layer below the second pad electrode layer may be an adhesion promoting layer, wherein the second pad electrode layer may be formed of a low resistive material compared with materials of the first and third pad electrode layers, and wherein the third pad electrode layer above the second pad electrode layer may serve the purpose of an etch stopper or the second pad electrode layer.

[0030] In another aspect, an organic light-emitting diode (OLED) display device comprises a substrate including a display area and a pad area; a pad line and a pad electrode in the pad area; and a patterned anode, configured by etching, in the display area, wherein the pad electrode may be a three-layered structure, wherein an uppermost layer and a lowermost layer of the three-layered structure may be of the same material, and wherein the uppermost layer may not be etched by an etchant which may be used to pattern the anode, and may be formed of a material to prevent corrosion of an intermediate layer of the three-layered structure.

[0031] In another aspect, a method of fabricating an organic light-emitting diode (OLED) display device comprises forming a thin film transistor on a display area of a substrate; forming a pad electrode having a three-layered structure on a pad area of the substrate; forming an open hole exposing a portion of an uppermost layer of the pad electrode by selectively etching a passivation layer on the pad area; and patterning an anode on the passivation layer over the thin film transistor by etching, wherein the uppermost layer exposed via the open hole may not be etched during the patterning of the anode.

[0032] It is to be understood that both the foregoing general description and the following detailed description are exemplary and explanatory and are intended to provide further explanation of the invention as claimed.

#### BRIEF DESCRIPTION OF THE DRAWINGS

[0033] The accompanying drawings, which are included to provide a further understanding of the disclosure and are incorporated in and constitute a part of this specification, illustrate exemplary embodiments and together with the description serve to explain the principles of the disclosure. In the drawings:

[0034] FIG. 1 is a diagram illustrating a light-emitting principle of a typical organic light-emitting diode (OLED);

[0035] FIG. 2 is a view illustrating a sub pixel structure of an OLED display device;

[0036] FIG. 3 is a perspective view exemplarily illustrating a structure of an OLED display device in accordance with a first embodiment of the present invention;

[0037] FIGS. 4A and 4B are sectional views schematically illustrating a partial structure of the OLED display device in accordance with the first embodiment of the present invention;

[0038] FIGS. 5A and 5B are sectional views schematically illustrating a partial structure of an OLED display device in accordance with a second embodiment of the present invention;

[0039] FIGS. 6A to 6J are sectional views sequentially illustrating a method of fabricating the OLED display device according to the second embodiment illustrated in FIG. 5A;

[0040] FIGS. 7A to 7G are sectional views sequentially illustrating a method of fabricating the OLED display device according to the second embodiment illustrated in FIG. 5B;

[0041] FIGS. 8A and 8B are sectional views schematically illustrating a partial structure of an OLED display device in accordance with a third embodiment of the present invention;

[0042] FIGS. 9A and 9B are sectional views schematically illustrating a partial structure of an OLED display device in accordance with a fourth embodiment of the present invention;

[0043] FIGS. 10A and 10B are sectional views schematically illustrating a partial structure of an OLED display device in accordance with a fifth embodiment of the present invention;

[0044] FIGS. 11A to 11J are sectional views sequentially illustrating a method of fabricating the OLED display device according to the fifth embodiment illustrated in FIG. 10A; and

[0045] FIGS. 12A to 12F are sectional views sequentially illustrating a method of fabricating the OLED display device according to the fifth embodiment illustrated in FIG. 10B.

#### DETAILED DESCRIPTION OF THE DISCLOSURE

[0046] Description will now be given in detail of certain embodiments of an organic light-emitting diode (OLED) display device and a method of fabricating the same according to the present invention, with reference to the accompanying drawings.

[0047] Advantages and features of the present invention and methods of achieving those will be understood with reference to the accompanying drawings and exemplary embodiments to be explained later in detail. Exemplary embodiments of the inventive concepts may, however, be embodied in many different forms and should not be construed as being limited to the embodiments set forth herein; rather, these embodiments are provided so that this disclosure will be thorough and complete, and will fully convey the concepts of the example embodiments to those of ordinary skill in the art. The same/like reference symbols can refer to the same/like components throughout the specification. In the drawings, the thicknesses of layers and regions may have been exaggerated for clarity.

[0048] It will be understood that when an element is referred to as being "on" another element, the element can be located on the other element or intervening elements may also be present. In contrast, when an element is referred to as being "directly on" another element, there are no intervening elements present.

**[0049]** Spatially relative terms, such as “beneath,” “below,” “lower,” “above,” “upper” and the like, may be used herein for ease of description to describe one element or feature’s relationship to another element(s) or feature(s) as illustrated in the drawings. It will be understood that the spatially relative terms are intended to encompass different orientations of the device in use or operation in addition to the orientation depicted in the drawings. For example, if the device in the drawings is turned over, elements described as “below” or “beneath” other elements or features would then be oriented “above” the other elements or features. Thus, the exemplary term “below” can encompass both an orientation of above and below.

**[0050]** The terminology used herein is for the purpose of describing particular embodiments only and is not intended to be limiting of the example embodiments unless otherwise stated. As used herein, the singular forms are intended to include the plural forms as well, unless the context clearly indicates otherwise. It will be further understood that the terms “comprises”, “comprising”, “includes” and/or “including,” if used herein, specify the presence of stated steps, operations, elements and/or components, but do not preclude the presence or addition of one or more other features, integers, steps, operations, elements, components and/or groups thereof.

**[0051]** FIG. 2 is a view illustrating a sub pixel structure of an OLED display device.

**[0052]** As illustrated in FIG. 2, an OLED display device includes a sub pixel region which is defined by a gate line GL arranged in a first direction, a data line DL arranged in a second direction, intersecting with the first direction, with being spaced apart from the gate line GL, and a driving power line VDDL. Alternatively, sub pixel regions can be defined by other means irrespective of the gate lines and data lines.

**[0053]** One sub pixel region may include a switching thin film transistor (TFT) ST, a driving TFT DT, a storage capacitor C and an OLED.

**[0054]** The switching TFT ST is switched (or otherwise operated) in response to a gate signal applied to the gate line GL to supply a data signal, which is supplied to the data line DL, to the driving TFT DT.

**[0055]** The driving TFT DT is switched (or otherwise operated) in response to the data signal supplied from the switching TFT ST, to control a current flowing from the driving power line VDDL to the OLED.

**[0056]** The storage capacitor C is connected between a gate electrode of the driving TFT DT and a base power line VSSL to hold (or store) a voltage corresponding to the data signal supplied to the gate electrode of the driving TFT DT, and constantly maintains a turn-on state of the driving TFT DT for one frame by use of the stored voltage.

**[0057]** The OLED is electrically connected between a source electrode or a drain electrode of the driving TFT DT and the base power line VSSL, to emit light by means of organic material that reacts to the current corresponding to the data signal supplied from the driving TFT DT.

**[0058]** FIG. 3 is a perspective view exemplarily illustrating a structure of an OLED display device in accordance with a first embodiment of the present invention. Here, FIG. 3 exemplarily illustrates an OLED display device with a flexible printed circuit board (FPCB) coupled to a pad area thereof. Such FPCB may be implemented in different forms and be labeled as various names, but all such configurations serve the purpose of providing an interface (via the pad area) between

a panel having various OLED components thereon and external circuits (i.e. circuits not on the panel itself) that provide signals and control to such panel. Here, the panel may be relatively rigid (typically made of glass) or relatively flexible (typically made of plastic), which is selectively used depending upon the type and application of the OLED display device to which such panel will be implemented in.

**[0059]** FIGS. 4A and 4B are sectional views schematically illustrating a partial structure of the OLED display device in accordance with the first embodiment of the present invention.

**[0060]** Here, FIG. 4A exemplarily illustrates one sub pixel including a TFT part and a capacitor forming part of the OLED display device, and FIG. 4B exemplarily illustrates parts of a gate pad area and a data pad area in a sequential manner.

**[0061]** Specifically, FIG. 4A illustrates an example of a top emission type OLED display device using a coplanar TFT. However, the present invention may not be limited to the coplanar TFT. Other types of TFT structures, such as a staggered TFT, can be implemented as well. Additionally, a plurality of transistor types can be implemented on a single panel or substrate (MTSS: Multiple TFTs on Single Substrate), whereby two or more types of different transistors based on different active materials, such as amorphous silicon, polysilicon (including low temperature polysilicon: LTPS), oxide semi-conductive materials (oxide TFTs), organic materials (O-TFTs), etc., which allow various TFT combinations to be used on a single panel or substrate in order to take advantage of each type of transistor’s advantageous characteristics.

**[0062]** Referring to FIG. 3, the OLED display device according to the first embodiment of the present invention may include a panel assembly 100 used in displaying images, and an FPCB 140 coupled to the panel assembly 100 to allow signals and control to be sent and received with other circuits and components.

**[0063]** The panel assembly 100 may include a (TFT) substrate 110 on which a display area (or active area, AA) and a pad area (or non-active area) are defined, and an encapsulation layer 120 on the (TFT) substrate 110 for encapsulating the display area AA.

**[0064]** Here, the pad area (in its entirety or portions thereof) may be exposed without being encapsulated by the encapsulation layer 120.

**[0065]** The substrate 110 having an array of TFTs, OLEDs and the like thereon is a base substrate and may be implemented as a polyimide substrate. Here, a back plate 105 may be attached onto a rear surface of the substrate 110.

**[0066]** A polarizer for preventing reflection of incident light coming from outside the panel assembly may be attached on the encapsulation layer 120.

**[0067]** Here, sub pixels are arranged in a matrix or array configuration on the display area AA of the substrate 110. On an outside of the display area AA (i.e. at the non-display area) may be located driving elements, such as a scan driver and a data driver for driving the sub pixels, and other components.

**[0068]** Hereinafter, the display area AA of the substrate 110 is described in detail with reference to FIG. 4A. As illustrated in FIG. 4A, the OLED display device according to the first embodiment of the present invention may include a substrate 110, a driving TFT DT, an OLED and an auxiliary electrode line VSSLa.

[0069] The driving TFT DT includes a semiconductor layer 124, a gate electrode 121, a source electrode 122 and a drain electrode 123.

[0070] The semiconductor layer 124 is formed on a substrate 110 which is made of an insulating material, such as silicon Si, glass, transparent plastic or a polymer film. But it is not limited to this. In other words, the substrate 110 may be formed from any material capable of supporting various layers and elements.

[0071] The semiconductor layer 124 may be made of amorphous silicon, polycrystalline silicon with crystallized amorphous silicon, oxide semiconductor, organic semiconductor and the like.

[0072] Here, a buffer layer may be located between the substrate 110 and the semiconductor layer 124. The buffer layer may be formed to protect the TFTs, which are formed in subsequent processes, from impurities such as alkaline ions discharged from the substrate 110.

[0073] A gate insulating layer 115a, which is made of silicon nitride SiN<sub>x</sub> or silicon dioxide (SiO<sub>2</sub>) (or silicon oxide), is formed on the semiconductor layer 124, and a gate line including the gate electrode 121 and a lower sustaining electrode 109 are formed on the gate insulating layer 115a.

[0074] The gate insulating layer 115a may be formed in the display area and the pad area. In other words, the gate insulating layer 115a may be formed on the entire surface of the substrate 110 provided with the semiconductor layer 124. But it is not limited to this.

[0075] The gate electrode 121 may be formed in such a manner as to overlap (or otherwise overlay, super-impose, cover, encroach, etc.) with the semiconductor layer 124 within the display area.

[0076] The gate electrode 121 and the gate line may be formed in a single body united (or integrated) with each other.

[0077] The gate electrode 121, the gate line and the lower sustaining electrode 109 may be formed of a first metallic material having a low resistance characteristic, such as aluminum (Al), copper (Cu), molybdenum (Mo), chrome (Cr), gold (Au), titanium (Ti), nickel (Ni), neodymium (Nd), or alloy thereof.

[0078] Although the gate electrode 121, the gate line and the lower sustaining electrode 109 are depicted to be formed as a single layer, they may be formed in a multi-layered structure including at least two layers.

[0079] An inter-layer insulating layer 115b which is made of silicon nitride, silicon oxide or silicon dioxide can be provided on the gate electrode 121, the gate line and the lower sustaining electrode 109. On the inter-layer insulating layer 115b, a data line, a driving voltage line, source and drain electrodes 122 and 123 and an upper sustaining electrode 119 can be provided.

[0080] Also, a plurality of contact holes (or other type of openings, vias, etc.) may be formed in the inter-layer insulating layer 115b.

[0081] The source electrode 122 and the drain electrode 123 are spaced apart from each other by a predetermined interval, and electrically connected to the semiconductor layer 124, respectively. In more detail, a semiconductor layer contact hole through which a part of the semiconductor layer 124 is exposed is formed through the gate insulating layer 115a and the inter-layer insulating layer 115b, such that the source and drain electrodes 122 and 123 can be electrically connected to the semiconductor layer 124.

[0082] The source electrode 122 and the data line may be formed in a single body united (or integrated) with each other.

[0083] Although the data line, the driving voltage line, the source and drain electrodes 122 and 123 and the upper sustaining electrode 119 are depicted to be formed in a single layer, they may be formed in a multi-layered structure including at least two layers.

[0084] Here, the upper sustaining electrode 119 overlaps (or otherwise overlays, super-imposes, covers, encroaches, etc.) a part of the lower sustaining electrode 109 with the inter-layer insulating layer 115b interposed therebetween, thereby forming a storage capacitor.

[0085] The data line, the driving voltage line, the source and drain electrodes 122 and 123 and the upper sustaining electrode 119 may be formed into a single layer or a multi-layer which is made of a second metallic material having a low resistance characteristic, such as aluminum (Al), copper (Cu), molybdenum (Mo), chrome (Cr), gold (Au), titanium (Ti), nickel (Ni), neodymium (Nd), or alloy thereof.

[0086] A passivation layer 115c and a planarization layer 115d are provided on the substrate 110 including the data line, the driving voltage line, the source and drain electrodes 122 and 123 and the upper sustaining electrode 119.

[0087] The passivation layer 115c may be formed on the entire surface of the substrate 110 including both of the display area and the pad area. The planarization layer 115d may be formed on the display area in which the TFT is formed.

[0088] Next, the OLED may include a first electrode 118, an organic compound layer 130 and a second electrode 128.

[0089] The OLED is electrically connected to the driving TFT DT. In more detail, a drain contact hole through which the drain electrode 123 of the driving TFT DT is exposed is formed through the passivation layer 115c and the planarization layer 115d which are located on the driving TFT DT. The OLED is electrically connected to the drain electrode 123 of the driving TFT DT through the drain contact hole.

[0090] That is, the first electrode 118 is provided on the planarization layer 115d, and electrically connected to the drain electrode 123 of the driving TFT DT through the drain contact hole.

[0091] The first electrode 118 is to supply a current (or a voltage) to the organic compound layer 130, and defines a light-emitting region with a predetermined area (or size).

[0092] The first electrode 118 serves as an anode. Accordingly, the first electrode 118 may include a transparent conductive material with a relatively high work function. Also, the first electrode 118 may be formed in a multi-layered structure including a plurality of electrode layers. For example, the first electrode 118 may be formed in a three-layered structure which is prepared by sequentially stacking a first electrode layer 118a, a second electrode layer 118b and third electrode layer 118c. The first electrode layer 118a may increase the adhesive strength of the second electrode layer 118b. The first electrode layer 118a may be formed of Indium Tin Oxide (ITO) or Indium Zinc Oxide (IZO). To improve reflectivity, the second electrode layer 118b may be a reflection layer made of a metal with high reflectivity. Examples of the metal having the high reflectivity may include aluminum (Al), silver (Ag), gold (Au), platinum (Pt), chrome (Cr) or alloy thereof.

[0093] The third electrode layer 118c may have a high work function. As such, the first electrode 118 may be used as the anode electrode. Such a third electrode layer 118c may be a transparent conductive layer. For example, the third electrode

layer **118c** may be formed from ITO or IZO. However, the present invention may not be limited to this.

[0094] A bank **115e** (or other structure serving a similar purpose) is formed on the substrate **110** having the first electrode **118**. Here, the bank **115e** defines a first opening by surrounding an edge region of the first electrode **118** like a bank. The bank **115e** may be made of an organic or inorganic insulating material. The bank **115e** may also be made of a photosensitive material containing black pigments. In this instance, the bank **115e** serves as a shielding member.

[0095] The bank **115e** may be formed to surround edges of the first electrode **118**. As such, any corrosion of the edges of the first electrode **118** may be prevented.

[0096] Here, in the first embodiment of the present invention, the bank **115e** further includes a second opening through which an auxiliary electrode **125** to be explained later is partially exposed.

[0097] The organic compound layer **130** is provided between the first electrode **118** and the second electrode **128**. The organic compound layer **130** emits light as holes supplied from the first electrode **118** and electrons supplied from the second electrode **128** are coupled to each other.

[0098] Here, FIG. 4A illustrates an example that the organic compound layer **130** is formed on an entire surface of the substrate **110**. However, the present invention may not be limited to this. The organic compound layer **130** may also be formed on the first electrode **118**.

[0099] Although it is shown in FIG. 4A that the organic compound layer **130** is formed in a single layer, the organic compound layer **130** is not limited to this. The organic compound layer **130** may have a multi-layered structure including a light-emitting layer to emit light and an auxiliary layer for improving light-emission efficiency of the light-emitting layer.

[0100] The second electrode **128** is provided on the organic compound layer **130** to supply electrons to the organic compound layer **130**.

[0101] The second electrode **128** serves as a cathode. Accordingly, the second electrode **128** may be made of a transparent conductive material. An example of the transparent conductive material may include ITO or IZO. The second electrode **128** may further include a thin metal layer which is provided at a side contactable with the organic compound layer **130** and is formed of a metal with a low work function. Examples of metals with the low work function may include magnesium (Mg), silver (Ag) and compounds thereof.

[0102] For the top emission type OLED display device, the second electrode **128** is formed to be relatively thin in thickness in order to meet the requirements of low work function and semi-transmittance. Therefore, the second electrode **128** has increased resistance, which causes a voltage drop (IR drop).

[0103] In the first embodiment of the present invention, in order to lower the voltage drop by reducing the resistance of the second electrode **128**, an auxiliary electrode line VSSLa is formed on the same layer as the first electrode **118**. The auxiliary electrode line VSSLa may include the auxiliary electrode **125** and a barrier wall **135**.

[0104] The auxiliary electrode **125** and the first electrode **118** are formed on the same layer. The auxiliary electrode **125** is spaced apart from the first electrode **118**. For example, the auxiliary electrode **125** may extend along in one direction to be connected to an external VSS pad.

[0105] The auxiliary electrode **125** may be implemented as a three-layered structure of a first auxiliary electrode layer **125a**, a second auxiliary electrode layer **125b** and a third auxiliary electrode layer **125c**, which is substantially the same as the structure of the first electrode **118**. In this instance, upon depositing the second electrode **128**, the second electrode **128** may come in contact directly with the third auxiliary electrode layer **125c** of the auxiliary electrode **125**. That is, the second electrode **128** is deposited even to a lower portion of the barrier wall **135** so as to come in contact with the auxiliary electrode **125**. However, the present invention may not be limited to this.

[0106] The barrier wall **135** is located on the auxiliary electrode **125**.

[0107] Here, the barrier wall **135** may have a reverse tapering shape that its cross-section is reduced from its top to bottom. For example, an angle formed by a side surface of the barrier wall **135** and the auxiliary electrode **125** may be in the range of 20 to 80°. This reverse tapering shape having the angle at the side surface may result in a shading effect to be explained later.

[0108] The barrier wall **135** forms an electrode contact hole through the organic compound layer **130** so as to expose the auxiliary electrode **125** therethrough. The organic compound layer **130** is formed on a top of the barrier wall **135**, but not formed below the top the barrier wall **135** by the shading effect. That is, the organic compound layer **130** is deposited on the substrate **110** by evaporation with directionality. Here, the organic compound layer **130** is not formed below the top of the barrier wall **140** because of the reverse tapering shape of the barrier wall **135**. Accordingly, the electrode contact hole is formed through the organic compound layer **130**.

[0109] The organic compound layer **130** and the second electrode **128** are sequentially deposited (laminated) on the barrier wall **135**.

[0110] The pad area is an edge area of the TFT substrate **110** having the display area. The pad area includes a gate pad area and a data pad area.

[0111] Referring to FIG. 4B, a gate pad electrode **126p** and a data pad electrode **127p** which are electrically connected to the gate line and the data line, respectively, are located on the gate pad area and the data pad area. The gate pad electrode **126p** and the data pad electrode **127p** transfer a scan signal and a data signal applied from an external driving circuit to the gate line and the data line, respectively.

[0112] That is, the gate line and the data line extend toward a driving circuit to be connected to corresponding gate pad line **116p** and data pad line **117p**, respectively. The gate pad line **116p** and the data pad line **117p** are electrically connected to the gate pad electrode **126p** and the data pad electrode **127p** through a gate pad line pattern **116p'** and a data pad line pattern **117p'**. Therefore, the gate line and the data line receive the scan signal and the data signal, respectively, applied from the driving circuit through the gate pad electrode **126p** and the data pad electrode **127p**.

[0113] The gate pad line **116p** and the gate line may be formed in a single body united with each other.

[0114] Moreover, the gate pad line **116p** and the data pad line **117p** may be formed through the same process as the gate line and the gate electrode **121**.

[0115] The data pad line pattern **117p'** and the data line may be formed in a single body united with each other.

[0116] Also, the gate pad line pattern **116p'** and the data pad line pattern **117p'** may be formed through the same process as the data line and the source and drain electrodes **122** and **123**.

[0117] Here, although the gate pad line **116p** and the data pad line **117p** are formed in a single layer, they may be formed in a multi-layered structure including at least two layers.

[0118] A plurality of contact holes exposing the gate pad line **116p** and the data pad line **117p** may be formed in the inter-layer insulating layer **115b** of the pad area. Also, a plurality of contact holes exposing the gate pad line pattern **116p'** and the data pad line pattern **117p'** may be formed in the passivation layer **115c** of the pad area.

[0119] Then, the gate pad electrode **126p** and the data pad electrode **127p** according to the first embodiment of the present invention may have substantially the same three-layered structure as the first electrode **118** and the auxiliary electrode **125** on the display area, for example, the three-layered structure of ITO/Ag alloy/ITO.

[0120] That is, the gate pad electrode **126p** according to the first embodiment of the present invention may include a first gate pad electrode layer **126pa**, a second gate pad electrode layer **126pb** and a third gate pad electrode layer **126pc**. The data pad electrode **127p** may have a three-layered structure of a first data pad electrode layer **127pa**, a second data pad electrode layer **127pb** and a third data pad electrode layer **127pc**.

[0121] In the OLED display device according to the first embodiment, when the second electrode layer **118b** of the first electrode **118** is formed of Ag or Ag alloy in order to improve reflectivity, the pad electrodes, namely, the gate pad electrode **126p** and the data pad electrode **127p** also have the structure of ITO/Ag or Ag alloy/ITO. Here, in the first embodiment, as the first pad electrode layers **126pa** and **127pa** made of ITO is located on the second pad electrode layers **126pb** and **127pb**, the corrosion of Ag or Ag due to an external moisture and oxygen may be prevented to some extent.

[0122] However, as sides of the second pad electrode layers **126pb** and **127pb** are exposed to an outside, the corrosion of Ag or Ag by an etchant during patterning of the first electrode **118** may occur. Thus there is a possibility of short-circuit problems with an adjacent line. Thus, the corrosion of the pad electrode **126p** and **127p** causes improper signal transfer from a driver driving circuit and may cause defects in the OLED display device.

[0123] Accordingly, in a second embodiment of the present invention, pad electrodes may be formed on a layer of a data line, and sides of the second pad electrode layers may be sealed by using a passivation layer (or of some other appropriate material or layer). Also, a three-layered structure of MoTi/Cu/MoTi having a particular etch selectivity with respect to an etchant used for etching Ag or Ag alloy may be applied to the pad electrodes of a pad area. This may result in preventing damage on the pad electrodes due to the etchant during patterning of a first electrode. Hereinafter, the second embodiment of the present invention will be described in detail with reference to the accompanying drawing.

[0124] Here, when the different kinds of the films are etched by the same etchant, etch selectivity results in one thin film being not etched and another thin film being etched. In other words, the film that may be etched has no etch selectivity, and the thin film that is not etched has etch selectivity.

[0125] Therefore, there are etching selectivity between Cu that may be etched by an etchant used for etching Ag or Ag

alloy and MoTi that is not etched by the etchant. That is, it is possible to avoid damage to the pad electrodes by the etchant during patterning of the first electrode by employing a three-layered structure of a MoTi/Cu/MoTi having etch selectivity to the pad electrodes of the pad area.

[0126] FIGS. **5A** and **5B** are sectional views schematically illustrating a partial structure of an OLED display device in accordance with a second embodiment of the present invention.

[0127] Here, FIG. **5A** illustrates one exemplary sub pixel including a TFT part and a capacitor forming part of an OLED display device, and FIG. **5B** sequentially illustrates parts of a gate pad area and a data pad area.

[0128] Specifically, FIG. **5A** illustrates one exemplary sub pixel of a top emission type OLED display device using a coplanar TFT, but the present invention may not be limited to the coplanar TFT.

[0129] Referring to FIG. **5A**, the top emission type OLED display device according to the second embodiment of the present invention includes a substrate **210**, a driving TFT DT, an OLED and an auxiliary electrode line VSSLa. But it is not limited to this. The present invention may not include the auxiliary electrode line VSSLa.

[0130] First, as the same as the first embodiment, the driving TFT DT includes a semiconductor layer **224**, a gate electrode **221**, a source electrode **222** and a drain electrode **223**.

[0131] The semiconductor layer **224** is formed on a substrate **210** which is made of an insulating material, such as silicon Si, glass, transparent plastic or a polymer film. But it is not limited to this. In other words, the substrate **210** may be formed from any material capable of supporting pluralities of layers and elements.

[0132] The semiconductor layer **224** may be made of amorphous silicon or polycrystalline silicon with crystallized amorphous silicon.

[0133] Here, a buffer layer may further be located between the substrate **210** and the semiconductor layer **224**. The buffer layer may be formed to protect the TFT from impurities such as alkaline ion discharged from the substrate **210** during crystallization of the semiconductor layer **224**.

[0134] A gate insulating layer **215a** which is made of silicon nitride (SiNx) or silicon dioxide (SiO<sub>2</sub>) is formed on the semiconductor layer **224**, and a gate line including the gate electrode **221** and a lower sustaining electrode **209** are formed on the gate insulating layer **215a**.

[0135] The gate insulating layer **215a** may be formed in the display area and the pad area. In other words, the gate insulating layer **215a** may be formed on the entire surface of the substrate **210** provided with the semiconductor layer **224**. But it is not limited to this.

[0136] The gate electrode **221** may be formed in such a manner as to overlap with the semiconductor layer **224** within the display area.

[0137] The gate electrode **221** and the gate line may be formed in a single body united with each other.

[0138] The gate electrode **221**, the gate line and the lower sustaining electrode **209** may be formed into a single layer or a multilayer made of a first metallic material having a low resistance characteristic, such as aluminum (Al), copper (Cu), molybdenum (Mo), chrome (Cr), gold (Au), titanium (Ti), nickel (Ni), neodymium (Nd), or alloy thereof.

[0139] Although the gate electrode 221, the gate line and the lower sustaining electrode 209 are formed in a single layer, they may be formed in a multi-layered structure including at least two layers.

[0140] An inter-layer insulating layer 215b which is made of silicon nitride or silicon dioxide is provided on the gate electrode 221, the gate line and the lower sustaining electrode 209. On the inter-layer insulating layer 215b are provided a data line, a driving voltage line, source and drain electrodes 222 and 223 and an upper sustaining electrode 219.

[0141] Also, a plurality of contact holes may be formed in the inter-layer insulating layer 215b.

[0142] The source electrode 222 and the drain electrode 223 are spaced apart from each other by a predetermined interval, and electrically connected to the semiconductor layer 224. In more detail, a semiconductor layer contact hole through which the semiconductor layer 224 is exposed is formed through the gate insulating layer 215a and the inter-layer insulating layer 215b, such that the source and drain electrodes 222 and 223 are electrically connected to the semiconductor layer 224.

[0143] The source electrode 222 and the data line may be formed in a single body united with each other.

[0144] Here, the upper sustaining electrode 219 overlaps a part of the lower sustaining electrode 209 with the inter-layer insulating layer 215b interposed therebetween, thereby forming a storage capacitor.

[0145] Here, the data line, the driving voltage line, the source and drain electrodes 222 and 223 and the upper sustaining electrode 219 according to the second embodiment of the present invention may have a multi-layered structure with three layers or more.

[0146] That is, the source electrode 222 may have a three-layered structure of a first source electrode layer 222a, a second source electrode layer 222b and a third source electrode layer 222c, and the drain electrode 223 may have a three-layered structure of a first drain electrode layer 223a, a second drain electrode layer 223b and a third drain electrode layer 223c.

[0147] The upper sustaining electrode 219 may also have a three-layered structure of a first upper sustaining electrode layer 219a, a second upper sustaining electrode layer 219b and a third upper sustaining electrode layer 219c.

[0148] The first source electrode layer 222a, the first drain electrode layer 223a and the first upper sustaining electrode layer 219a may be formed from the same material. Also, the first source electrode layer 222a, the first drain electrode layer 223a and the first upper sustaining electrode layer 219a may increase adhesive strengths of the second source electrode layer 222b, the second drain electrode layer 223b and the second upper sustaining electrode layer 219b.

[0149] For example, the first source electrode layer 222a, the first drain electrode layer 223a and the first upper sustaining electrode layer 219a may be formed from one of molybdenum titanium MoTi, titanium Ti and an alloy thereof.

[0150] The second source electrode layer 222b, the second drain electrode layer 223b and the second upper sustaining electrode layer 219b may be formed from the same material. Also, the second source electrode layer 222b, the second drain electrode layer 223b and the second upper sustaining electrode layer 219b may be formed from a low resistive material. For example, the second source electrode layer 222b, the second drain electrode layer 223b and the second upper sustaining electrode layer 219b may be formed from

one selected from a material group which includes aluminum Al, tungsten W, copper Cu, silver Ag, molybdenum Mo, chromium Cr, tantalum Ta, titanium Ti, or alloys thereof. Preferably, the second source electrode layer 222b, the second drain electrode layer 223b and the second upper sustaining electrode layer 219b may be formed from copper Cu.

[0151] The third source electrode layer 222c, the third drain electrode layer 223c and the third upper sustaining electrode layer 219c may be formed from the same material. Also, the third source electrode layer 222c, the third drain electrode layer 223c and the third upper sustaining electrode layer 219c may be formed from a material which is not corroded by moisture and oxygen in spite of being exposed to the exterior. For example, the third source electrode layer 222c, the third drain electrode layer 223c and the third upper sustaining electrode layer 219c may be formed from one of molybdenum titanium MoTi, titanium Ti or an alloy thereof.

[0152] For example, the data wiring according to the second embodiment of the present invention may have a three-layered structure of MoTi/Cu/MoTi.

[0153] A passivation layer 215c and a planarization layer 215d are provided on the substrate 210 having data line, the driving voltage line, the source and drain electrodes 222 and 223 and the upper sustaining electrode 219. The passivation layer 215c may be formed on the entire surface of the substrate 210 including both of the display area and the pad area. The planarization layer 215d may be formed on the display area in which the TFT is formed.

[0154] Next, the OLED may include a first electrode 218, an organic compound layer 230 and a second electrode 228.

[0155] The OLED is electrically connected to the driving TFT DT. In more detail, a drain contact hole through which the drain electrode 223 of the driving TFT DT is exposed is formed through the passivation layer 215c and the planarization layer 215d which are located on the driving TFT DT.

[0156] That is, the first electrode 218 is provided on the planarization layer 215d, and electrically connected to the drain electrode 223 of the driving TFT DT through the drain contact hole.

[0157] The first electrode 218 is to supply a current (or a voltage) to the organic compound layer 230, and defines a light-emitting region with a predetermined area (or size).

[0158] The first electrode 218 serves as an anode. Accordingly, the first electrode 218 may include a transparent conductive material with a relatively high work function. Also, the first electrode 218 may be formed in a multi-layered structure including a plurality of electrode layers. For example, the first electrode 218 may be formed in a three-layered structure which is prepared by sequentially stacking a first electrode layer 218a, a second electrode layer 218b and third electrode layer 218c.

[0159] The first electrode layer 218a may increase the adhesive strength of the second electrode layer 218b. The first electrode layer 218a may be formed of Indium Tin Oxide (ITO) or Indium Zinc Oxide (IZO). To improve reflectivity, the second electrode layer 218b may be a reflection layer made of a metal with high reflectivity. Examples of the metal having the high reflectivity may include aluminum (Al), silver (Ag), gold (Au), platinum (Pt), chrome (Cr) or alloy thereof.

[0160] The third electrode layer 218c may have a high work function. As such, the first electrode 218 may be used as the anode electrode. Such a third electrode layer 218c may be a transparent conductive layer. For example, the third electrode

layer **218c** may be formed from ITO or IZO. However, the present invention may not be limited to this.

[0161] A bank **215e** is formed on the substrate **210** having the first electrode **218**. Here, the bank **215e** defines a first opening by surrounding an edge of the first electrode **218** like a bank. The bank **215e** may be made of an organic or inorganic insulating material. The bank **215e** may also be made of a photosensitive material containing black pigments. In this instance, the bank **215e** serves as a shielding member.

[0162] The bank **215e** may be formed to surround edges of the first electrode **218**. As such, any corrosion of the edges of the first electrode **218** may be prevented.

[0163] Here, in the second embodiment of the present invention, the bank **215e** further include a second opening through which an auxiliary electrode **225** to be explained later is partially exposed.

[0164] The organic compound layer **230** is provided between the first electrode **218** and the second electrode **228**. The organic compound layer **230** emits light as holes supplied from the first electrode **218** and electrons supplied from the second electrode **228** are coupled to each other.

[0165] Here, FIG. 5A illustrates an example that the organic compound layer **230** is formed on an entire surface of the substrate **210**. However, the present invention may not be limited to this. The organic compound layer **230** may also be formed on the first electrode **218**.

[0166] Although it is shown in FIG. 5A that the organic compound layer **230** is formed in a single layer, the organic compound layer **230** is not limited to this. The organic compound layer **230** may have a multi-layered structure including a light-emitting layer to emit light and an auxiliary layer for improving light-emission efficiency of the light-emitting layer.

[0167] The second electrode **228** is formed on the organic compound layer **230** to supply electrons to the organic compound layer **230**.

[0168] The second electrode **228** serves as a cathode. Accordingly, the second electrode **228** may be made of a transparent conductive material. An example of the transparent conductive material may include ITO or IZO. The second electrode **228** may further include a metal layer which is provided at a side contactable with the organic compound layer **230** and is formed of a metal with a low work function. Examples of the metal with the low work function may include magnesium (Mg), silver (Ag) or a compound thereof.

[0169] As the same as the first embodiment of the present invention, an auxiliary electrode line VSSLa and the first electrode **218** are provided on the same layer to reduce resistance of the second electrode **228**. Here, the auxiliary electrode line VSSLa includes the auxiliary electrode **225** and the barrier wall **235**.

[0170] The auxiliary electrode **225** and the first electrode **218** are formed on the same layer. The auxiliary electrode **225** is spaced apart from the first electrode **218**. For example, the auxiliary electrode **225** may extend long in one direction to be connected to an external VSS pad.

[0171] The auxiliary electrode **225** may be implemented into a three-layered structure of a first auxiliary electrode layer **225a**, a second auxiliary electrode layer **225b** and a third auxiliary electrode layer **225c**, as substantially the same as the structure of the first electrode **218**. In this instance, upon depositing the second electrode **228**, the second electrode **228** may come in contact directly with the third auxiliary electrode layer **225c** of the auxiliary electrode **225**. That is, the

second electrode **228** is deposited even to a lower portion of the barrier wall **235** so as to come in contact with the auxiliary electrode **225**. However, the present invention may not be limited to this.

[0172] The barrier wall **235** is located on the auxiliary electrode **225**.

[0173] Here, the barrier wall **235** may have a tapering shape that its cross-section is reduced from its top to bottom. For example, an angle formed by a side surface of the barrier wall **235** and the auxiliary electrode **225** may be in the range of 20 to 80°. This reverse tapering shape having the angle at the side surface may derive a shading effect to be explained later.

[0174] The barrier wall **235** forms an electrode contact hole through the organic compound layer **230** so as to expose the auxiliary electrode **225** therethrough. The organic compound layer **230** is formed on a top of the barrier wall **235**, but not formed below the barrier wall **235** by the shading effect. Accordingly, the electrode contact hole is formed through the organic compound layer **230**.

[0175] The organic compound layer **230** and the second electrode **228** are sequentially stacked (laminated) on the barrier wall **235**.

[0176] The pad area is an edge area of the TFT substrate **210** having the display area. The pad area includes a gate pad area and a data pad area.

[0177] Referring to FIG. 5B, a gate pad electrode **226p** and a data pad electrode **227p** which are electrically connected to a gate line and a data line, respectively, are located on the gate pad area and the data pad area. The gate pad electrode **226p** and the data pad electrode **227p** transfer a scan signal and a data signal applied from an external driving circuit to the gate line and the data line, respectively.

[0178] That is, the gate line and the data line extend toward the driving circuit to be connected to corresponding gate pad line **216p** and data pad line **217p**, respectively. The gate pad line **216p** and the data pad line **217p** are electrically connected to the gate pad electrode **226p** and the data pad electrode **227p**, respectively. Therefore, the gate line and the data line receive the scan signal and the data signal, respectively, from the driving circuit through the gate pad electrode **226p** and the data pad electrode **227p**.

[0179] The gate pad line **216p** and the gate line may be formed in a single body united with each other.

[0180] Moreover, the gate pad line **216p** and the data pad line **217p** may be formed through the same process as the gate line and the gate electrode **221**.

[0181] The data pad electrode **227p** and the data line may be formed in a single body united with each other.

[0182] Also, the gate pad electrode **226p** and the data pad electrode **227p** may be formed through the same process as the data line and the source and drain electrodes **222** and **223**.

[0183] Here, although the gate pad line **216p** and the data pad line **217p** are formed in a single layer, they may be formed in a multi-layered structure including at least two layers.

[0184] A plurality of contact holes exposing the gate pad line **216p** and the data pad line **217p** may be formed in the inter-layer insulating layer **215b** of the pad area. Also, an open hole H exposing the gate pad electrode **226p** and the data pad electrode **227p** may be formed in the passivation layer **215c** of the pad area.

[0185] Then, the gate pad electrode **226p** and the data pad electrode **227p** according to the second embodiment of the present invention are formed on the same layer as the data line of the display area, here have substantially the same three-

layered structure as the data line, for example, the three-layered structure of MoTi/Cu/MoTi.

[0186] That is, in the second embodiment of the present invention, the three-layered structure of MoTi/Cu/MoTi having etch selectivity with respect to an etchant for etching Ag or Ag alloy is applied to the gate pad electrode **226p** and the data pad electrode **227p** of the pad area, and also parts of the gate pad electrode **226p** and the data pad electrode **227p** are externally exposed by forming an open hole H during patterning of the passivation layer **215c**.

[0187] In this instance, the upper MoTi may serve as an etch stopper of the etchant for etching Ag or Ag alloy.

[0188] Here, the gate pad electrode **226p** according to the second embodiment of the present invention may have the three-layered structure of a first gate pad electrode layer **226pa**, a second gate pad electrode layer **226pb** and a third gate pad electrode layer **226pc**, and the data pad electrode **227p** may have the three-layered structure of a first data pad electrode layer **227pa**, a second data pad electrode layer **227pb** and a third data pad electrode layer **227pc**.

[0189] The lowermost layers, i.e. the first gate pad electrode layer **226pa** and the first data pad electrode layer **227pa** may be an adhesion promoting layer increasing the adhesive strength of the second gate pad electrode layer **226pb** and the second data pad electrode layer **227pb**. That is, the first gate pad electrode layer **226pa** may be made of a material configured so as to increase the adhesion between the second gate pad electrode layer **226pb** and a fourth pad electrode layer, i.e. the gate pad line **216p**. Also, the first data pad electrode layer **227pa** may be made of a material configured so as to increase the adhesion between the second data pad electrode layer **227pb** and the data pad line **217p**.

[0190] The second gate pad electrode layer **226pb** and the second data pad electrode layer **227pb** may be formed from a low resistive material compared with the first gate pad electrode layer **226pa**, the first data pad electrode layer **227pa** and the third gate pad electrode layer **226pc**, the third data pad electrode layer **227pc**.

[0191] The pad electrodes **226p** and **227p** must be externally exposed for the connection with an external driver later. The pad electrodes **226p** and **227p** formed from copper Cu or others can be easy to transfer signals because of their low resistance. Meanwhile, the exposed pad electrodes **226p** and **227p** may be corroded by external moisture and oxygen. Moreover, the pad electrodes **226p** and **227p** formed from copper Cu or others can be etched by the etchant for patterning the first electrode **218** at the formation of the first electrode **218** which is performed for the formation of the OLED later.

[0192] To address this matter, the uppermost third pad electrode layers **226pc** and **227pc** may be formed from a material which is not corroded by oxygen and moisture, even though they are externally exposed. In other words, the third pad electrode layers **226pc** and **227pc** may be formed from a material being not etched by an etchant which may be used to form the first electrode **218**. For example, the third pad electrode layers **226pc** and **227pc** may be formed from one of molybdenum titanium MoTi, titanium Ti or an alloy thereof.

[0193] Also, the passivation layer **215c** may be formed in such a manner as to expose upper surfaces of the third pad electrode layers **226pc** and **227pc** of the pad electrodes **226p** and **227p**. In other words, the passivation layer **215c** may be formed in such a manner as to surround edges of the upper surfaces of the pad electrodes **226p** and **227p**. As such, any

corrosion of the sides of the pad electrodes **226p** and **227p** may be prevented. For example, the passivation layer **215c** may be formed in such a manner as to cover sides of the first pad electrode layers **226pc** and **227pa**, the second pad electrode layers **226pb** and **227pb** and the third pad electrode layers **226pc** and **227pc**, and at least some portions of the upper surfaces of the third pad electrode layers **226pc** and **227pc**.

[0194] Hereinafter, a method of fabricating an OLED display device according to the second embodiment of the present invention having the configuration will be described in detail with reference to the accompanying drawings.

[0195] FIGS. 6A to 6J are sectional views sequentially illustrating a method of fabricating the OLED display device according to the second embodiment illustrated in FIG. 5A, which sequentially illustrates a method of fabricating a TFT substrate of a display area.

[0196] And, FIGS. 7A to 7G are sectional views sequentially illustrating a method of fabricating the OLED display device according to the second embodiment illustrated in FIG. 5B, which sequentially illustrates a method of fabricating a TFT substrate of a pad area.

[0197] As illustrated in FIGS. 6A and 7A, a substrate **210** which is made of an insulating material, such as a transparent glass material, transparent plastic with high flexibility, a polymer film or the like is provided.

[0198] Although not illustrated, a TFT and a storage capacitor are formed on each of red, green and blue sub pixels of the substrate **210**.

[0199] First, a buffer layer is formed on the substrate **210**.

[0200] Here, the buffer layer may be formed to protect the TFT from impurities such as alkaline ion discharged from the substrate **110** during crystallization of a semiconductor layer. The buffer layer may be made of silicon dioxide.

[0201] Next, a semiconductor thin film is formed on the substrate **210** having the buffer layer.

[0202] The semiconductor thin film may be made of amorphous silicon, polycrystalline silicon, or oxide semiconductor.

[0203] Here, the polycrystalline silicon may be generated by employing various crystallization methods after depositing amorphous silicon on the substrate **210**. When the oxide semiconductor is used as the semiconductor thin film, the oxide semiconductor may be deposited, followed by a predetermined thermal treatment therefor.

[0204] Afterwards, the semiconductor thin film is selectively removed through a photolithography process to form a semiconductor layer **224**, which is formed of the semiconductor thin film, on the substrate **210** of the display area.

[0205] As illustrated in FIGS. 6B and 7B, a gate insulating layer **215a** and a first conductive layer are formed on the substrate **210** having the semiconductor layer **224**.

[0206] The gate insulating layer **215a** may be formed on the entire surface of the substrate **210** provided with the semiconductor layer **224**.

[0207] The first conductive layer may be provided to form a gate line, and made of a low-resistant opaque conductive material, such as aluminum (Al), copper (Cu), molybdenum (Mo), chrome (Cr), gold (Au), titanium (Ti), nickel (Ni), neodymium (Nd) or alloy thereof. However, these materials may have a multi-layered structure including two conductive layers which exhibit different physical properties. One of the conductive layers may be made of a metal with low resistivity,

for example, aluminum-based metal, silver-based metal, copper-based metal or the like, so as to reduce a signal delay or a voltage drop.

[0208] Afterwards, the first conductive layer is selectively removed through the photolithography process. Accordingly, a gate line including a gate electrode **221**, which is made of the first conductive layer, and a lower sustaining electrode **209** are formed on the substrate **210** of the display area, and also a gate pad line **216p** and a data pad line **217p**, which are formed of the first conductive layer, are formed on the substrate **210** on a pad area.

[0209] The gate electrode **221** may be formed in such a manner as to overlap with the semiconductor layer **224** within the display area.

[0210] The gate pad line **216p** and the gate line may be formed in a single body united with each other.

[0211] Although the gate electrode **221**, the gate line, the lower sustaining electrode **209** and the gate pad line **216p** are formed in a single layer, they may be formed in a multi-layered structure including at least two layers.

[0212] However, the present invention may not be limited to this. The gate line including the semiconductor layer **224** and the gate electrode **221**, the lower sustaining electrode **209**, the gate pad line **216p** and the data pad line **217p** may be simultaneously formed through one photolithography process.

[0213] Also, the lower gate insulating layer **215a** may also be patterned together during patterning of the gate line having the gate electrode **221**, the lower sustaining electrode **209**, the gate pad line **216p** and the data pad line **217p**.

[0214] Next, as illustrated in FIGS. **6C** and **7C**, an inter-layer insulating layer **215b**, which is made of silicon nitride or silicon dioxide is formed on the entire surface of the substrate **210** having the gate line having the gate electrode **221**, the lower sustaining electrode **209**, the gate pad line **216p** and the data pad line **217p**.

[0215] The inter-layer insulating layer **215b** may be formed on entire surface of the substrate **210**.

[0216] The inter-layer insulating layer **215b** and the gate insulating layer **215a** are selectively patterned through the photolithography. Accordingly, a first contact hole **250a** is formed such that a source/drain area of the semiconductor layer **224** is exposed therethrough, and also a second contact hole **250b** and a third contact hole **250c** are formed, respectively, such that parts of the gate pad line **216p** and the data pad line **217p** are exposed therethrough.

[0217] As illustrated in FIGS. **6D** and **7D**, after forming a second conductive layer, a third conductive layer and a fourth conductive layer on the entire surface of the substrate **210** having the inter-layer insulating layer **215b**, the second, third and fourth conductive layers are selectively removed through the photolithography process, thereby forming on the substrate **210** of the display area a data wiring (namely, source and drain electrodes **222** and **223**, a driving voltage line, a data line and an upper sustaining electrode **219**), which is made of the second, third and fourth conductive layers. That is, the data wiring may be formed in a multi-layered structure. For example, the data wiring may be formed in a three-layered structure.

[0218] The source electrode **222** may include a first source electrode layer **222a**, a second source electrode layer **222b** and a third source electrode layer **222c**. The drain electrode **223** may include a first drain electrode layer **223a**, a second drain electrode layer **223b** and a third drain electrode layer

**223c**. The upper sustaining electrode **219** may include an upper sustaining electrode layer **219a**, a second upper sustaining electrode layer **219b** and a third upper sustaining electrode layer **219c**.

[0219] Simultaneously, on the substrate **210** of the pad area is formed pad electrodes (namely, a gate pad electrode **226p** and a data pad electrode **227p**), which is made of the second, third and fourth conductive layers.

[0220] The gate pad electrode **226p** may include a first gate pad electrode layer **226pa**, a second gate pad electrode layer **226pb** and a third gate pad electrode layer **226pc**.

[0221] The data pad electrode **227p** may include a first data pad electrode layer **227pa**, a second data pad electrode layer **227pb** and a third data pad electrode layer **227pc**.

[0222] Here, the third conductive layer is made of a low-resistant opaque conductive material, such as aluminum (Al), copper (Cu), molybdenum (Mo), chrome (Cr), gold (Au), titanium (Ti), nickel (Ni), neodymium (Nd), or alloy thereof, in order to form the middle data line and pad electrode. However, these may have a multi-layered structure including two conductive layers which exhibit different physical properties. Specifically, in the second embodiment of the present invention, the third conductive layer may be made of Cu that can be etched by an etchant for etching Ag or Ag alloy.

[0223] Also, the second conductive layer may be made of MoTi in order to form the lower data line and the lower pad electrode. However, the present invention may not be limited to this. The second conductive layer may also be made of any other material if it can increase a contact characteristic with a lower layer. For example, the second conductive layer may be formed from one of molybdenum titanium MoTi, titanium Ti or an alloy thereof.

[0224] Here, the fourth conductive layer may be made of molybdenum titanium MoTi, titanium Ti or an alloy thereof in order to form the upper data line and pad electrode. However, the present invention may not be limited to this. The fourth conductive layer may also be made of any other material if it can be used as an etch stopper of an etchant for etching Ag or Ag alloy and may not be corroded by external moisture and oxygen. For example, the fourth conductive layer may be formed from one of molybdenum titanium MoTi, titanium Ti or an alloy thereof.

[0225] In this manner, a source electrode **222** which has a three-layered structure of the first source electrode layer **222a**, the second source electrode layer **222b** and the third source electrode layer **222c**, and a drain electrode **223** which has a three-layered structure of the first drain electrode layer **223a**, the second drain electrode layer **223b** and the third drain electrode layer **223c** may be formed on the substrate **210** of the display area.

[0226] Also, an upper sustaining electrode **219**, which has a three-layered structure of the first upper sustaining electrode layer **219a**, the second upper sustaining electrode layer **219b** and the third upper sustaining electrode layer **219c** may be formed on the lower sustaining electrode **209**.

[0227] Simultaneously, a gate pad electrode **226p** which has a three-layered structure of the first gate pad electrode layer **226pa**, the second gate pad electrode layer **226pb** and the third gate pad electrode layer **226pc**, and a data pad electrode **227p** which has a three-layered structure of the first data pad electrode layer **227pa**, the second data pad electrode layer **227pb** and the third data pad electrode layer **227pc** may be formed on the substrate **210** of the pad area.

[0228] Here, the data wiring and the pad electrode according to the second embodiment of the present invention may have the three-layered structure of MoTi/Cu/MoTi.

[0229] Here, the source and drain electrodes 222 and 223 are electrically connected to the source/drain area of the semiconductor layer 224 through the first contact hole. The upper sustaining electrode 219 overlaps a part of the lower sustaining electrode 209 with interposing the inter-layer insulating layer 215b therebetween, thereby forming a storage capacitor.

[0230] The gate pad electrode 226p and the data pad electrode 227p are electrically connected to the lower gate pad line 216p and data pad line 217p through the second and third contact holes, respectively.

[0231] Afterwards, as illustrated in FIGS. 6E and 7E, a passivation layer 215c which is made of silicon nitride or silicon dioxide is formed on the substrate 210 of the display area on which the source and drain electrodes 222 and 223, the driving voltage line, the data line, the upper sustaining electrode 219, the gate pad electrode 226p and the data pad electrode 227p are formed.

[0232] The passivation layer 215c may be formed on the entire surface of the substrate 210.

[0233] Here, a planarization layer 215d made of an organic insulating material may be formed on the passivation layer 215c, but the present invention may not be limited to this. The passivation layer may also function as the planarization layer.

[0234] Such the planarization layer may be formed using one of a halftone mask and a refractive mask. In this case, an insulation layer having a first planarization pattern 215d' with the large thickness and a second planarization pattern 215d'' with the small thickness may be formed on the entire surface of the substrate 210. In other words, the first planarization pattern 215d' may be formed to have a larger height than that of the second planarization pattern 215d''.

[0235] The first planarization pattern 215d' with the large thickness may be formed in the display area, and the second planarization pattern 215d'' with the small thickness may be formed in the pad area.

[0236] Then, as illustrated in FIGS. 6F and 7F, the passivation patterns 215d' and 215d'' are selectively patterned through the photolithography process, thereby forming a fourth contact hole 250d through which the drain electrode 223 is exposed, and an open hole H through which parts of the gate pad electrode 226p and the data pad electrode 227p are externally exposed.

[0237] As illustrated in FIGS. 6F and 7G, the second planarization pattern 215d'' with the small thickness is removed. At the same time, the first planarization pattern 215d' with the large thickness is removed by the thickness of the second planarization pattern 215d'', thereby forming a planarization layer 215d. In other words, when an ashing process is performed for the first planarization pattern 215d' with the large thickness can remain even though the second planarization pattern 215d'' with the small thickness is completely removed.

[0238] The first planarization pattern 215d' remaining after the ashing process may become the planarization layer 215d. As such, the planarization layer 215d may be formed in the display area without the pad area. In accordance therewith, the passivation layer 215c within the pad area may be exposed.

[0239] Next, as illustrated in FIG. 6G, fifth to seventh conductive layers are formed on the entire surface of the substrate 210 having the planarization layer 215d.

[0240] However, the present invention may not be limited to this. For example, the fifth conductive layer may also be formed as a single layer on the entire surface of the substrate 210 having the planarization layer 215d.

[0241] The fifth conductive layer and the seventh conductive layer may be made of a transparent conductive material, such as ITO or IZO.

[0242] The sixth conductive layer may be made of aluminum (Al), silver (Ag), gold (Au), platinum (Pt), chrome (Cr) or alloy thereof.

[0243] Afterwards, by selectively patterning the fifth to seventh conductive layers through the photolithography process, a first electrode 218 and an auxiliary electrode 225 made of the fifth to seventh conductive layers are formed.

[0244] Here, the first electrode 218 may include a first electrode layer 218a, a second electrode layer 218b and a third electrode layer 218c which are made of the fifth to seventh conductive layers, respectively.

[0245] The first electrode layer 218a may increase the adhesive strength of the second electrode layer 218b. For example, the first electrode layer 218a may be formed of Indium Tin Oxide (ITO) or Indium Zinc Oxide (IZO).

[0246] The second electrode layer 218b may be a reflection layer made of a metal with high reflectivity.

[0247] The third electrode layer 218c may have a high work function. As such, the first electrode 218 may be used as the anode electrode. Such a third electrode layer 218c may be a transparent conductive layer. For example, the third electrode layer 218c may be formed from ITO or IZO.

[0248] If the gate pad electrode 226p and the data pad electrode 227p are externally exposed at the formation of the first electrode 218, the gate pad electrode 226p and the data pad electrode 227p must be affected by an etchant for the first electrode 218. However, the third gate pad electrode layer 226pc and the third data pad electrode layer 227pc made of molybdenum titanium MoTi, titanium Ti or an alloy thereof, cannot be etched by the etchant for etching Ag or Ag alloy at the patterning of the first electrode 218.

[0249] In order to pattern the first electrode 218 formed of an Ag alloy, a phosphoric acid-based etchant, a nitric acid-based etchant, a phosphoric acid+nitric acid-based etchant, a phosphoric acid+acetic acid-based etchant, a nitric acid+acetic acid-based etchant, or a phosphoric acid+nitric acid+acetic acid-based etchant may be used. Moreover, in order to pattern the first electrode 218, an etchant that does not contain hydrofluoric acid potassium and hydrogen peroxide may be used.

[0250] For reference, Ag may be etched by phosphate or a nitrate anion (according to the following chemical reactions) so as to be precipitated.

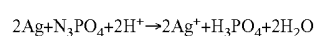
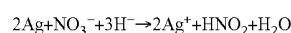

[0251] MoTi cannot be etched by the etchant for etching Ag or Ag alloy. In case of MoTi or Ti, a component of H<sub>2</sub>O<sub>2</sub>, F is required to be included in the etchant in order to perform the desired etching process.

[0252] An oxidation process with respect to H<sub>2</sub>O<sub>2</sub>-based materials (or H<sub>2</sub>O<sub>2</sub> group) is as follows.

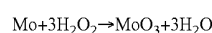

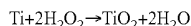

[0253] And,  $\text{MoO}_3$  and  $\text{TiO}_2$  are dissolved and etched by  $\text{F}^-$  ions as follows.

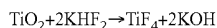
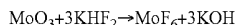

[0254] Alternatively, instead of forming an open hole (H) in the passivation layer 215c of the pad area, the open hole (H) may be formed in the passivation layer 215c using a photoresist pattern to form the bank. It may help prevent damage to the pad electrodes 226p and 227p by the patterning of the first electrode 218.

[0255] The auxiliary electrode 225 may include a first auxiliary electrode layer 225a, a second auxiliary electrode layer 225b and a third auxiliary electrode layer 225c which are made of the fifth to seventh conductive layers, respectively.

[0256] The first electrode 218 as an anode may be electrically connected to the drain electrode 223 of the driving TFT through the fourth contact hole.

[0257] Also, the first electrode 218 is formed on the substrate 210 to correspond to each of red, green and blue sub pixels.

[0258] Next, as illustrated in FIG. 6H, a predetermined bank 215e is formed on the substrate 210 of the display area having the first electrode 218 and the auxiliary electrode 225.

[0259] Here, the bank 215e defines an opening by surrounding an edge region of the first electrode 218 like a bank and is made of an organic or inorganic insulating material. The bank 215e may also be made of a photosensitive material containing black pigments, and in this instance, the bank 215e may serve as a shielding member.

[0260] Also, the bank 215e further includes a second opening through which the auxiliary electrode 225 is partially exposed.

[0261] Here, as described above, after the open hole (H) exposing the pad electrodes 226p and 227p is formed by using the photoresist pattern as a mask, the bank 215e for exposing a part of the first electrode 218 may be formed. In this case, the bank 215e may be formed by re-patterning the photoresist pattern using an additional mask process.

[0262] Alternatively, the bank 215e may be formed by partially removing the photoresist pattern without any additional mask process.

[0263] As illustrated in FIG. 6I, a barrier wall 235 is formed on the substrate 210 having the bank 215e.

[0264] The barrier wall 235 is located on the auxiliary electrode 225.

[0265] Here, the barrier wall 235 may have a reverse tapering shape that its section is reduced from top to bottom thereof. For example, an angle formed by a side surface of the barrier wall 235 and the auxiliary electrode 225 may be in the range of 20 to 80°. This reverse tapering shape having the angle at the side surface may derive a shading effect to be explained later.

[0266] Next, as illustrated in FIG. 6J, an organic compound layer 230 is formed on the substrate 210 having the barrier wall 235 by way of evaporation.

[0267] In this instance, the barrier wall 235 forms an electrode contact hole, through which the auxiliary electrode 225 is exposed, on the organic compound layer 230. The organic compound layer 230 is formed on the top the barrier wall 235, and not formed below the top of the barrier wall 235 by the

shading effect. Accordingly, the electrode contact hole is formed through the organic contact hole 230.

[0268] To this end, although not illustrated, a hole injection layer and a hole transport layer are sequentially formed on the substrate 210.

[0269] Here, the hole injection layer and the hole transport layer are commonly formed on each of the red, green and blue sub pixels, so as to allow for smooth injection and transport of the holes. Here, one of the hole injection layer and the hole transport layer may be omitted.

[0270] Next, a light-emitting layer is formed on the substrate 210 having the hole transport layer.

[0271] Here, the light-emitting layer may include a red light-emitting layer, a green light-emitting layer and a blue light-emitting layer to correspond to the red, green and blue sub pixels.

[0272] An electron transport layer is then formed on the substrate 210 having the light-emitting layer.

[0273] Here, the electron transport layer is commonly formed on each of the red, green and blue sub pixels on the light-emitting layer, so as to allow for smooth transport of the electrons.

[0274] Here, an electron injection layer for smooth injection of the electrons may further be formed on the electron transport layer.

[0275] A second electrode 228 made of an eighth conductive layer is formed on the substrate 210 having the electron transport layer in a sputtering manner.

[0276] Here, the eighth conductive layer is deposited even to a lower portion of the barrier wall 235 such that the second electrode 228 can come in contact with the auxiliary electrode 225.

[0277] The thusly-fabricated OLED is encapsulated by a predetermined thin film encapsulation layer.

[0278] A polarization film for reducing reflection of external light of the OLED display device so as to improve a contrast ratio may be provided on the thin film encapsulation layer.

[0279] FIGS. 8A and 8B are sectional views schematically illustrating a partial structure of an OLED display device in accordance with a third embodiment of the present invention.

[0280] Here, the configuration of the OLED display device in accordance with the third embodiment of the present invention (except for a gate pad electrode and a data pad electrode formed of a gate wiring and a data wiring, respectively, in a layer of the gate wiring) is substantially the same as the configuration of the aforementioned OLED display device in accordance with the second embodiment of the present invention.

[0281] FIG. 8A illustrates one exemplary sub pixel including a TFT part and a capacitor forming part of an OLED display device, and FIG. 8B sequentially illustrates parts of a gate pad area and a data pad area.

[0282] Specifically, FIG. 8A illustrates one exemplary sub pixel of a top emission type OLED display device using a coplanar TFT, but the present invention may not be limited to the coplanar TFT.

[0283] Referring to FIG. 8A, the top emission type OLED display device according to the third embodiment of the present invention includes a substrate 310, a driving TFT DT, an OLED and an auxiliary electrode line VSSLa. But it is not limited to this. The present invention may not include the auxiliary electrode line VSSLa.

[0284] First, as the same as the first and second embodiments, the driving TFT DT includes a semiconductor layer 324, a gate electrode 321, a source electrode 322 and a drain electrode 323.

[0285] The semiconductor layer 324 is formed on a substrate 310 which is made of an insulating material, such as silicon Si, glass, transparent plastic or a polymer film. But it is not limited to this. In other words, the substrate 310 may be formed from any material capable of supporting pluralities of layers and elements.

[0286] The semiconductor layer 324 may be made of amorphous silicon or polycrystalline silicon with crystallized amorphous silicon.

[0287] Here, a buffer layer may further be located between the substrate 310 and the semiconductor layer 324. The buffer layer may be formed to protect the TFT from impurities such as alkaline ion discharged from the substrate 310 during crystallization of the semiconductor layer 324.

[0288] A gate insulating layer 315a which is made of silicon nitride (SiNx) or silicon dioxide (SiO<sub>2</sub>) is formed on the semiconductor layer 324, and a gate line including the gate electrode 321 and a lower sustaining electrode 309 are formed on the gate insulating layer 315a.

[0289] The gate insulating layer 315a may be formed in the display area and the pad area. In other words, the gate insulating layer 315a may be formed on the entire surface of the substrate 310 provided with the semiconductor layer 324. But it is not limited to this.

[0290] The gate electrode 321 may be formed in such a manner as to overlap with the semiconductor layer 324 within the display area.

[0291] The gate electrode 321 and the gate line may be formed in a single body united with each other.

[0292] The gate electrode 321, the gate line and the lower sustaining electrode 309 may be formed in a multi-layered structure including at least two layers.

[0293] For example, the gate electrode 321 may have a three-layered structure of a first gate electrode 321a, a second gate electrode 321b and a third gate electrode 321c. The lower sustaining electrode 309 may also have a three-layered structure of a first lower sustaining electrode 309a, a second lower sustaining electrode 309b and a third lower sustaining electrode 309c.

[0294] The first gate electrode 321a and the first lower sustaining electrode 309a may be formed from the same material. Also, the first gate electrode 321a and the first lower sustaining electrode 309a may increase adhesive strengths of the second gate electrode 321b and the second lower sustaining electrode 309b, respectively.

[0295] For example, the first gate electrode 321a and the first lower sustaining electrode 309a may be formed from one of molybdenum titanium MoTi, titanium Ti or an alloy thereof.

[0296] The second gate electrode 321b and the second lower sustaining electrode 309b may be formed from the same material. Also, the second gate electrode 321b and the second lower sustaining electrode 309b may be formed from a low resistive material. For example, the second gate electrode 321b and the second lower sustaining electrode 309b may be formed from one selected from a material group which includes aluminum Al, tungsten W, copper Cu, silver Ag, molybdenum Mo, chromium Cr, tantalum Ta, titanium

Ti, or alloys thereof. Preferably, the second gate electrode 321b and the second lower sustaining electrode 309b may be formed from copper Cu.

[0297] The third gate electrode 321c and the third lower sustaining electrode 309c may be formed from the same material. Also, the third gate electrode 321c and the third lower sustaining electrode 309c may be formed from a material which is not corroded by moisture and oxygen in spite of being exposed to the exterior. For example, the third gate electrode 321c and the third lower sustaining electrode 309c may be formed from one of molybdenum titanium MoTi, titanium Ti or an alloy thereof.

[0298] For example, the gate wiring according to the third embodiment of the present invention may have a three-layered structure of MoTi/Cu/MoTi.

[0299] An inter-layer insulating layer 315b which is made of silicon nitride or silicon dioxide is provided on the gate electrode 321, the gate line and the lower sustaining electrode 309. On the inter-layer insulating layer 315b are provided a data line, a driving voltage line, source and drain electrodes 322 and 323 and an upper sustaining electrode 319.

[0300] Also, a plurality of contact holes may be formed in the inter-layer insulating layer 315b.

[0301] The source electrode 322 and the drain electrode 323 are spaced apart from each other by a predetermined interval, and electrically connected to the semiconductor layer 324. In more detail, a semiconductor layer contact hole through which the semiconductor layer 324 is exposed is formed through the gate insulating layer 315a and the inter-layer insulating layer 315b, such that the source and drain electrodes 322 and 323 are electrically connected to the semiconductor layer 324.

[0302] The source electrode 322 and the data line may be formed in a single body united with each other.

[0303] Here, the upper sustaining electrode 319 overlaps a part of the lower sustaining electrode 309 with the inter-layer insulating layer 315b interposed therebetween, thereby forming a storage capacitor.

[0304] Here, the data line, the driving voltage line, the source and drain electrodes 322 and 323 and the upper sustaining electrode 319 according to the third embodiment of the present invention may have a multi-layered structure with three layers or more.

[0305] That is, the source electrode 322 may have a three-layered structure of a first source electrode layer 322a, a second source electrode layer 322b and a third source electrode layer 322c, and the drain electrode 323 may have a three-layered structure of a first drain electrode layer 323a, a second drain electrode layer 323b and a third drain electrode layer 323c.

[0306] The upper sustaining electrode 319 may also have a three-layered structure of a first upper sustaining electrode layer 319a, a second upper sustaining electrode layer 319b and a third upper sustaining electrode layer 319c.

[0307] The first source electrode layer 322a, the first drain electrode layer 323a and the first upper sustaining electrode layer 319a may be formed from the same material. Also, the first source electrode layer 322a, the first drain electrode layer 323a and the first upper sustaining electrode layer 319a may increase adhesive strengths of the second source electrode layer 322b, the second drain electrode layer 323b and the second upper sustaining electrode layer 319b.

[0308] For example, the first source electrode layer 322a, the first drain electrode layer 323a and the first upper sustain-

ing electrode layer **319a** may be formed from one of molybdenum titanium MoTi, titanium Ti or an alloy thereof.

[0309] The second source electrode layer **322b**, the second drain electrode layer **323b** and the second upper sustaining electrode layer **319b** may be formed from the same material. Also, the second source electrode layer **322b**, the second drain electrode layer **323b** and the second upper sustaining electrode layer **319b** may be formed from a low resistive material. For example, the second source electrode layer **322b**, the second drain electrode layer **323b** and the second upper sustaining electrode layer **319b** may be formed from one selected from a material group which includes aluminum Al, tungsten W, copper Cu, silver Ag, molybdenum Mo, chromium Cr, tantalum Ta, titanium Ti, or alloys thereof. Preferably, the second source electrode layer **322b**, the second drain electrode layer **323b** and the second upper sustaining electrode layer **319b** may be formed from copper Cu.

[0310] The third source electrode layer **322c**, the third drain electrode layer **323c** and the third upper sustaining electrode layer **319c** may be formed from the same material. Also, the third source electrode layer **322c**, the third drain electrode layer **323c** and the third upper sustaining electrode layer **319c** may be formed from a material which is not corroded by moisture and oxygen in spite of being exposed to the exterior. For example, the third source electrode layer **322c**, the third drain electrode layer **323c** and the third upper sustaining electrode layer **319c** may be formed from one of molybdenum titanium MoTi, titanium Ti or an alloy thereof.

[0311] For example, the data wiring according to the third embodiment of the present invention may have a three-layered structure of MoTi/Cu/MoTi.

[0312] A passivation layer **315c** and a planarization layer **315d** are provided on the substrate **310** having data line, the driving voltage line, the source and drain electrodes **322** and **323** and the upper sustaining electrode **319**. The passivation layer **315c** may be formed on the entire surface of the substrate **310** including both of the display area and the pad area. The planarization layer **315d** may be formed on the display area in which the TFT is formed.

[0313] Next, the OLED may include a first electrode **318**, an organic compound layer **330** and a second electrode **328**.

[0314] The OLED is electrically connected to the driving TFT DT. In more detail, a drain contact hole through which the drain electrode **323** of the driving TFT DT is exposed is formed through the passivation layer **315c** and the planarization layer **315d** which are located on the driving TFT DT.

[0315] That is, the first electrode **318** is provided on the planarization layer **315d**, and electrically connected to the drain electrode **323** of the driving TFT DT through the drain contact hole.

[0316] The first electrode **318** is to supply a current (or a voltage) to the organic compound layer **330**, and defines a light-emitting region with a predetermined area (or size).

[0317] The first electrode **318** serves as an anode. Accordingly, the first electrode **318** may include a transparent conductive material with a relatively great work function. Also, the first electrode **318** may be formed in a multi-layered structure including a plurality of electrode layers. For example, the first electrode **318** may be formed in a three-layered structure which is prepared by sequentially stacking a first electrode layer **318a**, a second electrode layer **318b** and third electrode layer **318c**.

[0318] The first electrode layer **318a** may increase the adhesive strength of the second electrode layer **318b**. The first

electrode layer **318a** may be formed of Indium Tin Oxide (ITO) or Indium Zinc Oxide (IZO). To improve reflectivity, the second electrode layer **318b** may be a reflection layer made of a metal with high reflectivity. Examples of the metal having the high reflectivity may include aluminum (Al), silver (Ag), gold (Au), platinum (Pt), chrome (Cr) or alloy thereof.

[0319] The third electrode layer **318c** may have a high work function. As such, the first electrode **318** may be used as the anode electrode. Such a third electrode layer **318c** may be a transparent conductive layer. For example, the third electrode layer **318c** may be formed from ITO or IZO. However, the present invention may not be limited to this.

[0320] A bank **315e** is formed on the substrate **310** having the first electrode **318**. Here, the bank **315e** defines a first opening by surrounding an edge of the first electrode **318** like a bank. The bank **315e** may be made of an organic or inorganic insulating material. The bank **315e** may also be made of a photosensitive material containing black pigments. In this instance, the bank **315e** serves as a shielding member.

[0321] The bank **315e** may be formed to surround edges of the first electrode **318**. As such, any corrosion of the edges of the first electrode **318** may be prevented.

[0322] Here, in the third embodiment of the present invention, the bank **315e** further include a second opening through which an auxiliary electrode **325** to be explained later is partially exposed.

[0323] The organic compound layer **330** is provided between the first electrode **318** and the second electrode **328**.

[0324] Here, FIG. 8A illustrates an example that the organic compound layer **330** is formed on an entire surface of the substrate **310**. However, the present invention may not be limited to this. The organic compound layer **330** may also be formed on the first electrode **318**.

[0325] Although it is shown in FIG. 8A that the organic compound layer **330** is formed in a single layer, the organic compound layer **330** is not limited to this. The organic compound layer **330** may have a multi-layered structure including a light-emitting layer to emit light and an auxiliary layer for improving light-emission efficiency of the light-emitting layer.

[0326] The second electrode **328** is formed on the organic compound layer **330** to supply electrons to the organic compound layer **330**.

[0327] The second electrode **328** serves as a cathode. Accordingly, the second electrode **328** may be made of a transparent conductive material. An example of the transparent conductive material may include ITO or IZO. The second electrode **328** may further include a metal layer which is provided at a side contactable with the organic compound layer **330** and is formed of a metal with a low work function. Examples of the metal with the low work function may include magnesium (Mg), silver (Ag) and a compound thereof.

[0328] As the same as the first and second embodiments of the present invention, an auxiliary electrode line VSSLa and the first electrode **318** are provided on the same layer to reduce resistance of the second electrode **328**. Here, the auxiliary electrode line VSSLa includes the auxiliary electrode **325** and the barrier wall **335**.

[0329] The auxiliary electrode **325** and the first electrode **318** are formed on the same layer. The auxiliary electrode **325** is spaced apart from the first electrode **318**. For example, the

auxiliary electrode **325** may extend long in one direction to be connected to an external VSS pad.

[0330] The auxiliary electrode **325** may be implemented into a three-layered structure of a first auxiliary electrode layer **325a**, a second auxiliary electrode layer **325b** and a third auxiliary electrode layer **325c**, as substantially the same as the structure of the first electrode **318**. In this instance, upon depositing the second electrode **328**, the second electrode **328** may come in contact directly with the third auxiliary electrode layer **325c** of the auxiliary electrode **325**. That is, the second electrode **328** is deposited even to a lower portion of the barrier wall **335** so as to come in contact with the auxiliary electrode **325**. However, the present invention may not be limited to this.

[0331] The barrier wall **335** is located on the auxiliary electrode **325**.

[0332] Here, the barrier wall **335** may have a tapering shape that its cross-section is reduced from top to bottom thereof. For example, an angle formed by a side surface of the barrier wall **335** and the auxiliary electrode **325** may be in the range of 20 to 80°. This reverse tapering shape having the angle at the side surface may derive a shading effect to be explained later.

[0333] The barrier wall **335** forms an electrode contact hole through the organic compound layer **330** so as to expose the auxiliary electrode **325** therethrough. The organic compound layer **330** is formed on a top of the barrier wall **335**, but not formed below the barrier wall **335** by the shading effect. Accordingly, the electrode contact hole is formed through the organic compound layer **330**.

[0334] The organic compound layer **330** and the second electrode **328** are sequentially stacked (laminated) on the barrier wall **335**.

[0335] The pad area is an edge area of the TFT substrate **310** having the display area. The pad area includes a gate pad area and a data pad area.

[0336] Referring to FIG. 8B, a gate pad electrode **326p** and a data pad electrode **327p** which are electrically connected to a gate line and a data line, respectively, are located on the gate pad area and the data pad area. The gate pad electrode **326p** and the data pad electrode **327p** transfer a scan signal and a data signal applied from an external driving circuit to the gate line and the data line, respectively.

[0337] That is, the gate line and the data line extend toward the driving circuit to be connected to corresponding gate pad line **316p** and data pad line **317p**, respectively. The gate pad line **316p** and the data pad line **317p** are electrically connected to the gate pad electrode **326p** and the data pad electrode **327p**, respectively. Therefore, the gate line and the data line receive the scan signal and the data signal, respectively, from the driving circuit through the gate pad electrode **326p** and the data pad electrode **327p**.

[0338] The gate pad electrode **326p** and the gate line may be formed in a single body united with each other.

[0339] Moreover, the gate pad electrode **326p** may be formed through the same process as the gate line and the gate electrode **321**.

[0340] The data pad electrode **327p** and the data line may be formed in a single body united with each other.

[0341] Also, the data pad electrode **327p** may be formed through the same process as the data line and the source and drain electrodes **322** and **323**.

[0342] An open hole H exposing the gate pad electrode **326p** and the data pad electrode **327p** may be formed in the inter-layer insulating layer **315b** and the passivation layer **315c** of the pad area.

[0343] Then, the gate pad electrode **326p** and the data pad electrode **327p** according to the third embodiment of the present invention are formed on the same layer as the gate wiring of the display area, here have substantially the same three-layered structure as the gate wiring and the data wiring, respectively, for example the three-layered structure of MoTi/Cu/MoTi.

[0344] That is, in the third embodiment of the present invention, the three-layered structure of MoTi/Cu/MoTi having etch selectivity with respect to an etchant for etching Ag or Ag alloy is applied to the gate pad electrode **326p** and the data pad electrode **327p** of the pad area, and also parts of the gate pad electrode **326p** and the data pad electrode **327p** are externally exposed by forming an open hole H during patterning of the passivation layer **315c**.

[0345] In this instance, the upper MoTi may serve as an etch stopper of the etchant for etching Ag or Ag alloy.

[0346] As described above, in order to pattern the first electrode **318**, a phosphoric acid-based etchant, a nitric acid-based etchant, a phosphoric acid+nitric acid-based etchant, a phosphoric acid+acetic acid-based etchant, a nitric acid+acetic acid-based etchant, or a phosphoric acid+nitric acid+acetic acid-based etchant may be used. Also, in order to pattern the first electrode **318**, an etchant that does not contain hydrofluoric acid potassium and hydrogen peroxide may be used.

[0347] Here, the gate pad electrode **326p** according to the third embodiment of the present invention may have the three-layered structure of a first gate pad electrode layer **326pa**, a second gate pad electrode layer **326pb** and a third gate pad electrode layer **326pc**, and the data pad electrode **327p** may have the three-layered structure of a first data pad electrode layer **327pa**, a second data pad electrode layer **327pb** and a third data pad electrode layer **327pc**.

[0348] The lowermost layers, i.e. the first gate pad electrode layer **326pa** and the first data pad electrode layer **327pa** may be an adhesion promoting layer increasing the adhesive strength of the second gate pad electrode layer **326pb** and the second data pad electrode layer **327pb**.

[0349] The second gate pad electrode layer **326pb** and the second data pad electrode layer **327pb** may be formed from a low resistive material compared with the first gate pad electrode layer **326pa**, the first data pad electrode layer **327pa** and the third gate pad electrode layer **326pc**, the third data pad electrode layer **327pc**.

[0350] As described above, the uppermost third pad electrode layers **326pc** and **327pc** may be formed from a material which is not corroded by oxygen and moisture, even though they are externally exposed. In other words, the third pad electrode layers **326pc** and **327pc** may be formed from a material being not etched by an etchant which may be used to form the first electrode **318**. For example, the third pad electrode layers **326pc** and **327pc** may be formed from one of molybdenum titanium MoTi, titanium Ti or an alloy thereof.

[0351] Also, the passivation layer **315c** may be formed in such a manner as to expose upper surfaces of the third pad electrode layers **326pc** and **327pc** of the pad electrodes **326p** and **327p**. In this case, the passivation layer **315c** may be formed in such a manner as to cover entire surfaces of the pad electrodes **326p** and **327p** except for the exposed third pad

electrode layers **326pc** and **327pc**. As such, any corrosion of the sides of the third pad electrode layers **326pc** and **327pc** may be prevented. For example, the passivation layer **315c** may be formed in such a manner as to cover sides of the first pad electrode layers **326pa** and **327pa**, the second pad electrode layers **326pb** and **327pb** and the third pad electrode layers **326pc** and **327pc**, and at least some portions of the upper surfaces of the third pad electrode layers **326pc** and **327pc**.

[0352] FIGS. 9A and 9B are sectional views schematically illustrating a partial structure of an OLED display device in accordance with a fourth embodiment of the present invention.

[0353] Here, the configuration of the OLED display device in accordance with the fourth embodiment of the present invention (except for a gate pad electrode and a data pad electrode formed of a gate wiring in a layer of the gate wiring) is substantially the same as the configuration of the aforementioned OLED display device in accordance with the second and third embodiments of the present invention.

[0354] FIG. 9A illustrates one exemplary sub pixel including a TFT part and a capacitor forming part of an OLED display device, and FIG. 9B sequentially illustrates parts of a gate pad area and a data pad area.

[0355] Specifically, FIG. 9A illustrates one exemplary sub pixel of a top emission type OLED display device using a coplanar TFT, but the present invention may not be limited to the coplanar TFT.

[0356] Referring to FIG. 9A, the top emission type OLED display device according to the fourth embodiment of the present invention includes a substrate **410**, a driving TFT DT, an OLED and an auxiliary electrode line VSSLa. But it is not limited to this. The present invention may not include the auxiliary electrode line VSSLa.

[0357] First, as the same as the first, second and third embodiments, the driving TFT DT includes a semiconductor layer **424**, a gate electrode **421**, a source electrode **422** and a drain electrode **423**.

[0358] The semiconductor layer **424** is formed on a substrate **410** which is made of an insulating material, such as silicon Si, glass, transparent plastic or a polymer film. But it is not limited to this. In other words, the substrate **410** may be formed from any material capable of supporting pluralities of layers and elements.

[0359] The semiconductor layer **424** may be made of amorphous silicon or polycrystalline silicon with crystallized amorphous silicon.

[0360] Here, a buffer layer may further be located between the substrate **410** and the semiconductor layer **424**. The buffer layer may be formed to protect the TFT from impurities such as alkaline ion discharged from the substrate **410** during crystallization of the semiconductor layer **424**.

[0361] A gate insulating layer **415a** which is made of silicon nitride (SiNx) or silicon dioxide (SiO<sub>2</sub>) is formed on the semiconductor layer **424**, and a gate line including the gate electrode **421** and a lower sustaining electrode **409** are formed on the gate insulating layer **415a**.

[0362] The gate insulating layer **415a** may be formed in the display area and the pad area. In other words, the gate insulating layer **415a** may be formed on the entire surface of the substrate **410** provided with the semiconductor layer **424**. But it is not limited to this.

[0363] The gate electrode **421** may be formed in such a manner as to overlap with the semiconductor layer **424** within the display area.

[0364] The gate electrode **421** and the gate line may be formed in a single body united with each other.

[0365] The gate electrode **421**, the gate line and the lower sustaining electrode **409** may be formed in a multi-layered structure including at least two layers.

[0366] For example, the gate electrode **421** may have a three-layered structure of a first gate electrode **421a**, a second gate electrode **421b** and a third gate electrode **421c**. The lower sustaining electrode **409** may also have a three-layered structure of a first lower sustaining electrode **409a**, a second lower sustaining electrode **409b** and a third lower sustaining electrode **409c**.

[0367] The first gate electrode **421a** and the first lower sustaining electrode **409a** may be formed from the same material. Also, the first gate electrode **421a** and the first lower sustaining electrode **409a** may increase adhesive strengths of the second gate electrode **421b** and the second lower sustaining electrode **409b**, respectively.

[0368] For example, the first gate electrode **421a** and the first lower sustaining electrode **409a** may be formed from one of molybdenum titanium MoTi, titanium Ti or an alloy thereof.

[0369] The second gate electrode **421b** and the second lower sustaining electrode **409b** may be formed from the same material. Also, the second gate electrode **421b** and the second lower sustaining electrode **409b** may be formed from a low resistive material. For example, the second gate electrode **421b** and the second lower sustaining electrode **409b** may be formed from one selected from a material group which includes aluminum Al, tungsten W, copper Cu, silver Ag, molybdenum Mo, chromium Cr, tantalum Ta, titanium Ti, or alloys thereof. Preferably, the second gate electrode **421b** and the second lower sustaining electrode **409b** may be formed from copper Cu.

[0370] The third gate electrode **421c** and the third lower sustaining electrode **409c** may be formed from the same material. Also, the third gate electrode **421c** and the third lower sustaining electrode **409c** may be formed from a material which is not corroded by moisture and oxygen in spite of being exposed to the exterior. For example, the third gate electrode **421c** and the third lower sustaining electrode **409c** may be formed from one of molybdenum titanium MoTi, titanium Ti or an alloy thereof.

[0371] For example, the gate wiring according to the fourth embodiment of the present invention may have a three-layered structure of MoTi/Cu/MoTi.

[0372] An inter-layer insulating layer **415b** which is made of silicon nitride or silicon dioxide is provided on the gate electrode **421**, the gate line and the lower sustaining electrode **409**. On the inter-layer insulating layer **415b** are provided a data line, a driving voltage line, source and drain electrodes **422** and **423** and an upper sustaining electrode **419**.

[0373] Also, a plurality of contact holes may be formed in the inter-layer insulating layer **415b**.

[0374] The source electrode **422** and the drain electrode **423** are spaced apart from each other by a predetermined interval, and electrically connected to the semiconductor layer **424**. In more detail, a semiconductor layer contact hole through which the semiconductor layer **424** is exposed is formed through the gate insulating layer **415a** and the inter-

layer insulating layer **415b**, such that the source and drain electrodes **422** and **423** are electrically connected to the semiconductor layer **424**.

[0375] The source electrode **422** and the data line may be formed in a single body united with each other.

[0376] Here, the upper sustaining electrode **419** overlaps a part of the lower sustaining electrode **409** with the inter-layer insulating layer **415b** interposed therebetween, thereby forming a storage capacitor.

[0377] The data line, the driving voltage line, the source and drain electrodes **422** and **423** and the upper sustaining electrode **419** according to the fourth embodiment of the present invention may be formed into a single layer or a multilayer made of a second metallic material having a low resistance characteristic, such as aluminum (Al), copper (Cu), molybdenum (Mo), chrome (Cr), gold (Au), titanium (Ti), nickel (Ni), neodymium (Nd), or alloy thereof.

[0378] A passivation layer **415c** and a planarization layer **415d** are provided on the substrate **410** having data line, the driving voltage line, the source and drain electrodes **422** and **423** and the upper sustaining electrode **419**. The passivation layer **415c** may be formed on the display area and the data pad area. The planarization layer **415d** may be formed on the display area in which the TFT is formed.

[0379] Next, the OLED may include a first electrode **418**, an organic compound layer **430** and a second electrode **428**.

[0380] The OLED is electrically connected to the driving TFT DT. In more detail, a drain contact hole through which the drain electrode **423** of the driving TFT DT is exposed is formed through the passivation layer **415c** and the planarization layer **415d** which are located on the driving TFT DT.

[0381] That is, the first electrode **418** is provided on the planarization layer **415d**, and electrically connected to the drain electrode **423** of the driving TFT DT through the drain contact hole.

[0382] The first electrode **418** is to supply a current (or a voltage) to the organic compound layer **430**, and defines a light-emitting region with a predetermined area (or size).

[0383] The first electrode **418** serves as an anode. Accordingly, the first electrode **418** may include a transparent conductive material with a relatively great work function. Also, the first electrode **418** may be formed in a multi-layered structure including a plurality of electrode layers. For example, the first electrode **418** may be formed in a three-layered structure which is prepared by sequentially stacking a first electrode layer **418a**, a second electrode layer **418b** and third electrode layer **418c**.

[0384] The first electrode layer **418a** may increase the adhesive strength of the second electrode layer **418b**. The first electrode layer **418a** may be formed of Indium Tin Oxide (ITO) or Indium Zinc Oxide (IZO). To improve reflectivity, the second electrode layer **418b** may be a reflection layer made of a metal with high reflectivity. Examples of the metal having the high reflectivity may include aluminum (Al), silver (Ag), gold (Au), platinum (Pt), chrome (Cr) or alloy thereof.

[0385] The third electrode layer **418c** may have a high work function. As such, the first electrode **418** may be used as the anode electrode. Such a third electrode layer **418c** may be a transparent conductive layer. For example, the third electrode layer **418c** may be formed from ITO or IZO. However, the present invention may not be limited to this.

[0386] A bank **415e** is formed on the substrate **410** having the first electrode **418**. Here, the bank **415e** defines a first

opening by surrounding an edge of the first electrode **418** like a bank. The bank **415e** may be made of an organic or inorganic insulating material. The bank **415e** may also be made of a photosensitive material containing black pigments. In this instance, the bank **415e** serves as a shielding member.

[0387] The bank **415e** may be formed to surround edges of the first electrode **418**. As such, any corrosion of the edges of the first electrode **418** may be prevented.

[0388] Here, in the fourth embodiment of the present invention, the bank **415e** further include a second opening through which an auxiliary electrode **425** to be explained later is partially exposed.

[0389] The organic compound layer **430** is provided between the first electrode **418** and the second electrode **428**.

[0390] Here, FIG. 9A illustrates an example that the organic compound layer **430** is formed on an entire surface of the substrate **410**. However, the present invention may not be limited to this. The organic compound layer **430** may also be formed on the first electrode **418**.

[0391] Although it is shown in FIG. 9A that the organic compound layer **430** is formed in a single layer, the organic compound layer **430** is not limited to this. The organic compound layer **430** may have a multi-layered structure including a light-emitting layer to emit light and an auxiliary layer for improving light-emission efficiency of the light-emitting layer.

[0392] The second electrode **428** is formed on the organic compound layer **430** to supply electrons to the organic compound layer **430**.

[0393] The second electrode **428** serves as a cathode. Accordingly, the second electrode **428** may be made of a transparent conductive material. An example of the transparent conductive material may include ITO or IZO. The second electrode **428** may include a metal layer which is contactable with the organic compound layer **430** and is formed of a metal with a low work function. Examples of the metal with the low work function may include magnesium (Mg), silver (Ag) or a compound thereof.

[0394] As the same as the first, second and third embodiments of the present invention, an auxiliary electrode line VSSLa and the first electrode **418** are provided on the same layer to reduce resistance of the second electrode **428**. Here, the auxiliary electrode line VSSLa includes the auxiliary electrode **425** and the barrier wall **435**.

[0395] The auxiliary electrode **425** and the first electrode **418** are formed on the same layer. The auxiliary electrode **425** is spaced apart from the first electrode **418**. For example, the auxiliary electrode **425** may extend long in one direction to be connected to an external VSS pad.

[0396] The auxiliary electrode **425** may be implemented into a three-layered structure of a first auxiliary electrode layer **425a**, a second auxiliary electrode layer **425b** and a third auxiliary electrode layer **425c**, as substantially the same as the structure of the first electrode **418**. In this instance, upon depositing the second electrode **428**, the second electrode **428** may come in contact directly with the third auxiliary electrode layer **425c** of the auxiliary electrode **425**. That is, the second electrode **428** is deposited even to a lower portion of the barrier wall **435** so as to come in contact with the auxiliary electrode **425**. However, the present invention may not be limited to this.

[0397] The barrier wall **435** is located on the auxiliary electrode **425**.

[0398] Here, the barrier wall 435 may have a tapering shape that its cross-section is reduced from top to bottom thereof. For example, an angle formed by a side surface of the barrier wall 435 and the auxiliary electrode 425 may be in the range of 20 to 80°. This reverse tapering shape having the angle at the side surface may derive a shading effect to be explained later.

[0399] The barrier wall 435 forms an electrode contact hole through the organic compound layer 430 so as to expose the auxiliary electrode 425 therethrough. The organic compound layer 430 is formed on a top of the barrier wall 435, but not formed below the barrier wall 435 by the shading effect. Accordingly, the electrode contact hole is formed through the organic compound layer 430.

[0400] The organic compound layer 430 and the second electrode 428 are sequentially stacked (laminated) on the barrier wall 435.

[0401] The pad area is an edge area of the TFT substrate 410 having the display area. The pad area includes a gate pad area and a data pad area.

[0402] Referring to FIG. 9B, a gate pad electrode 426p and a data pad electrode 427p which are electrically connected to a gate line and a data line, respectively, are located on the gate pad area and the data pad area. The gate pad electrode 426p and the data pad electrode 427p transfer a scan signal and a data signal applied from an external driving circuit to the gate line and the data line, respectively.

[0403] That is, the gate line and the data line extend toward the driving circuit to be connected to corresponding gate pad electrode 426p and the data pad electrode 427p, respectively. Therefore, the gate line and the data line receive the scan signal and the data signal, respectively, from the driving circuit through the gate pad electrode 426p and the data pad electrode 427p.

[0404] The gate pad electrode 426p and the gate line may be formed in a single body united with each other.

[0405] On the other hand, the data pad electrode 427p may be electrically connected with the data line via a connection wiring 460 formed in a layer of the gate wiring.

[0406] Moreover, the gate pad electrode 426p and the data pad electrode 427p may be formed through the same process as the gate line and the gate electrode 421. Also, the connection wiring 460 of the pad area may be formed through the same process as the data line and the source and drain electrodes 422 and 423.

[0407] An open hole H exposing the gate pad electrode 426p and the data pad electrode 427p may be formed in the inter-layer insulating layer 415b and the passivation layer 415c of the pad area. Thus, a portion of an upper surface of the data pad electrode 427p may be exposed to the outside through the open hole H, and the other portion of the upper surface of the data pad electrode 427p may be connected to the connection wiring 460 through a contact hole. The connection wiring 460 may be a data line which may be extended.

[0408] Also, the inter-layer insulating layer 415b of the pad area may be formed in such a manner as to surround (and sealing) the sides of the pad electrodes 426p and 427p. As such, any corrosion of the sides of the pad electrodes 426p and 427p may be prevented.

[0409] The gate pad electrode 426p and the data pad electrode 427p according to the fourth embodiment of the present invention may be formed on the same layer as the gate wiring of the display area, then have substantially the same three-

layered structure as the gate wiring, for example, the three-layered structure of MoTi/Cu/MoTi.

[0410] That is, in the third embodiment of the present invention, the three-layered structure of MoTi/Cu/MoTi having etch selectivity with respect to an etchant for etching Ag or Ag alloy is applied to the gate pad electrode 426p and the data pad electrode 427p of the pad area, and also parts of the gate pad electrode 426p and the data pad electrode 427p may be externally exposed by forming the open hole H during patterning of the passivation layer 415c.

[0411] In this instance, the upper MoTi may serve as an etch stopper of the etchant for etching Ag or Ag alloy.

[0412] As described above, in order to pattern the first electrode 418, a phosphoric acid-based etchant, a nitric acid-based etchant, a phosphoric acid+nitric acid-based etchant, a phosphoric acid+acetic acid-based etchant, a nitric acid+acetic acid-based etchant, or a phosphoric acid+nitric acid+acetic acid-based etchant may be used. Also, in order to pattern the first electrode 418, an etchant that does not contain hydrofluoric acid potassium and hydrogen peroxide may be used.

[0413] Here, the gate pad electrode 426p according to the fourth embodiment of the present invention may have the three-layered structure of a first gate pad electrode layer 426pa, a second gate pad electrode layer 426pb and a third gate pad electrode layer 426pc, and the data pad electrode 427p may have the three-layered structure of a first data pad electrode layer 427pa, a second data pad electrode layer 427pb and a third data pad electrode layer 427pc.

[0414] The lowermost layers, i.e. the first gate pad electrode layer 426pa and the first data pad electrode layer 427pa may be an adhesion promoting layer increasing the adhesive strength of the second gate pad electrode layer 426pb and the second data pad electrode layer 427pb.

[0415] The second gate pad electrode layer 426pb and the second data pad electrode layer 427pb may be formed from a low resistive material compared with the first gate pad electrode layer 426pa, the first data pad electrode layer 427pa and the third gate pad electrode layer 426pc, the third data pad electrode layer 427pc.

[0416] As described above, the uppermost third pad electrode layers 426pc and 427pc may be formed from a material which is not corroded by oxygen and moisture, even though they are externally exposed. In other words, the third pad electrode layers 426pc and 427pc may be formed from a material being not etched by an etchant which may be used to form the first electrode 418. For example, the third pad electrode layers 426pc and 427pc may be formed from one of molybdenum titanium MoTi, titanium Ti or an alloy thereof.

[0417] Also, the inter-layer insulating layer 415b and the passivation layer 415c may be formed in such a manner as to expose upper surfaces of the third pad electrode layers 426pc and 427pc of the pad electrodes 426p and 427p. In this case, the inter-layer insulating layer 415b may be formed in such a manner as to cover the entire surfaces of the pad electrodes 426p and 427p except for the exposed upper surface of the third gate pad electrode layer 426pc. As such, any corrosion of the sides of the third pad electrode layers 426pc and 427pc may be prevented. For example, the inter-layer insulating layer 415b may be formed in such a manner as to cover sides of the first pad electrode layers 426pc and 427pa, the second pad electrode layers 426pb and 427pb and the third pad elec-

trode layers **426pc** and **427pc**, and at least some portions of the upper surfaces of the third pad electrode layers **426pc** and **427pc**.

[0418] Here, when the etchant for etching Ag or Ag alloy permeates into a crack generated due to impurity or a crack which is generated during patterning of the passivation layer, it may damage Cu of the gate pad electrode and the data pad electrode. To prevent the damage, the fifth embodiment of the present invention employs a clad structure in which the third gate pad electrode layer and the third data pad electrode layer cover the first and second gate pad electrode layers and the first and second data pad electrode layers.

[0419] Also, such clad structure may be applicable to the pad electrodes of the first embodiment to the fourth embodiment as well.

[0420] In the clad structure, the uppermost layer, i.e. the third gate pad electrode layer and the third data pad electrode layer are in contact with both sides of the first and second gate pad electrode layers and the first and second data pad electrode layers, respectively, as well as to be in contact with upper surfaces of the second gate pad electrode layer and the second data pad electrode layer, respectively. Thus, the third gate pad electrode layer and the third data pad electrode layer are to seal the first and second gate pad electrode layers and the first and second data pad electrode layers.

[0421] Such structure provides several effects of improvement of reliability, reduction of defects and improvement of productivity.

[0422] Hereinafter, the fifth embodiment of the present invention will be described in detail with reference to the accompanying drawing.

[0423] FIGS. **10A** and **10B** are sectional views schematically illustrating a partial structure of an OLED display device in accordance with a fifth embodiment of the present invention.

[0424] Here, FIG. **10A** illustrates one exemplary sub pixel including a TFT part and a capacitor forming part of an OLED display device, and FIG. **10B** sequentially illustrates parts of a gate pad area and a data pad area.

[0425] Specifically, FIG. **10A** illustrates one exemplary sub pixel of a top emission type OLED display device using a coplanar TFT, but the present invention may not be limited to the coplanar TFT.

[0426] Referring to FIG. **10A**, the top emission type OLED display device according to the second embodiment of the present invention includes a substrate **510**, a driving TFT DT, an OLED and an auxiliary electrode line VSSLa. But it is not limited to this. The present invention may not include the auxiliary electrode line VSSLa.

[0427] First, as the same as the first to the fourth embodiments, the driving TFT DT includes a semiconductor layer **524**, a gate electrode **521**, a source electrode **522** and a drain electrode **523**.

[0428] The semiconductor layer **524** is formed on a substrate **510** which is made of an insulating material, such as silicon Si, glass, transparent plastic or a polymer film. But it is not limited to this. In other words, the substrate **510** may be formed from any material capable of supporting pluralities of layers and elements.

[0429] The semiconductor layer **524** may be made of amorphous silicon or polycrystalline silicon with crystallized amorphous silicon.

[0430] Here, a buffer layer may further be located between the substrate **510** and the semiconductor layer **524**. The buffer

layer may be formed to protect the TFT from impurities such as alkaline ion discharged from the substrate **510** during crystallization of the semiconductor layer **524**.

[0431] A gate insulating layer **515a** which is made of silicon nitride (SiNx) or silicon dioxide (SiO<sub>2</sub>) is formed on the semiconductor layer **524**, and a gate line including the gate electrode **521** and a lower sustaining electrode **509** are formed on the gate insulating layer **515a**.

[0432] The gate insulating layer **515a** may be formed in the display area and the pad area. In other words, the gate insulating layer **515a** may be formed on the entire surface of the substrate **510** provided with the semiconductor layer **524**. But it is not limited to this.

[0433] The gate electrode **521** may be formed in such a manner as to overlap with the semiconductor layer **524** within the display area.

[0434] The gate electrode **521** and the gate line may be formed in a single body united with each other.

[0435] The gate electrode **521**, the gate line and the lower sustaining electrode **509** may be formed into a single layer or a multilayer made of a first metallic material having a low resistance characteristic, such as aluminum (Al), copper (Cu), molybdenum (Mo), chrome (Cr), gold (Au), titanium (Ti), nickel (Ni), neodymium (Nd), or alloy thereof.

[0436] Although the gate electrode **521**, the gate line and the lower sustaining electrode **509** are formed in a single layer, they may be formed in a multi-layered structure including at least two layers.

[0437] An inter-layer insulating layer **515b** which is made of silicon nitride or silicon dioxide is provided on the gate electrode **521**, the gate line and the lower sustaining electrode **509**. On the inter-layer insulating layer **515b** are provided a data line, a driving voltage line, source and drain electrodes **522** and **523** and an upper sustaining electrode **519**. Also, a plurality of contact holes may be formed in the inter-layer insulating layer **515b**.

[0438] The source electrode **522** and the drain electrode **523** are spaced apart from each other by a predetermined interval, and electrically connected to the semiconductor layer **524**. In more detail, a semiconductor layer contact hole through which the semiconductor layer **524** is exposed is formed through the gate insulating layer **515a** and the inter-layer insulating layer **515b**, such that the source and drain electrodes **522** and **523** are electrically connected to the semiconductor layer **524**.

[0439] The source electrode **522** and the data line may be formed in a single body united with each other.

[0440] Here, the upper sustaining electrode **519** overlaps a part of the lower first sustaining electrode **509** with the inter-layer insulating layer **515b** interposed therebetween, thereby forming a storage capacitor.

[0441] Here, the data line, the driving voltage line, the source and drain electrodes **522** and **523** and the upper sustaining electrode **519** according to the fifth embodiment of the present invention may have a multi-layered structure with three layers or more.

[0442] That is, the source electrode **522** may have a three-layered structure of a first source electrode layer **522a**, a second source electrode layer **522b** and a third source electrode layer **522c**, and the drain electrode **523** may have a three-layered structure of a first drain electrode layer **523a**, a second drain electrode layer **523b** and a third drain electrode layer **523c**.

[0443] The upper sustaining electrode **519** may also have a three-layered structure of a first upper sustaining electrode layer **519a**, a second upper sustaining electrode layer **519b** and a third upper sustaining electrode layer **519c**.

[0444] The first source electrode layer **522a**, the first drain electrode layer **523a** and the first upper sustaining electrode layer **519a** may be formed from the same material. Also, the first source electrode layer **522a**, the first drain electrode layer **523a** and the first upper sustaining electrode layer **519a** may increase adhesive strengths of the second source electrode layer **522b**, the second drain electrode layer **523b** and the second upper sustaining electrode layer **519b**.

[0445] For example, the first source electrode layer **522a**, the first drain electrode layer **523a** and the first upper sustaining electrode layer **519a** may be formed from one of molybdenum titanium MoTi, titanium Ti or an alloy thereof.

[0446] The second source electrode layer **522b**, the second drain electrode layer **523b** and the second upper sustaining electrode layer **519b** may be formed from the same material. Also, the second source electrode layer **522b**, the second drain electrode layer **523b** and the second upper sustaining electrode layer **519b** may be formed from a low resistive material. For example, the second source electrode layer **522b**, the second drain electrode layer **523b** and the second upper sustaining electrode layer **519b** may be formed from one selected from a material group which includes aluminum Al, tungsten W, copper Cu, silver Ag, molybdenum Mo, chromium Cr, tantalum Ta, titanium Ti, or alloys thereof. Preferably, the second source electrode layer **522b**, the second drain electrode layer **523b** and the second upper sustaining electrode layer **519b** may be formed from copper Cu.

[0447] The third source electrode layer **522c**, the third drain electrode layer **523c** and the third upper sustaining electrode layer **519c** may be formed from the same material. Also, the third source electrode layer **522c**, the third drain electrode layer **523c** and the third upper sustaining electrode layer **519c** may be formed from a material which is not corroded by moisture and oxygen in spite of being exposed to the exterior. For example, the third source electrode layer **522c**, the third drain electrode layer **523c** and the third upper sustaining electrode layer **519c** may be formed from one of molybdenum titanium MoTi, titanium Ti or an alloy thereof.

[0448] For example, the data wiring according to the fifth embodiment of the present invention may have a three-layered structure of MoTi/Cu/MoTi.

[0449] A passivation layer **515c** and a planarization layer **515d** are provided on the substrate **510** having data line, the driving voltage line, the source and drain electrodes **522** and **523** and the upper sustaining electrode **519**.

[0450] Next, the OLED may include a first electrode **518**, an organic compound layer **530** and a second electrode **528**.

[0451] The OLED is electrically connected to the driving TFT DT. In more detail, a drain contact hole through which the drain electrode **523** of the driving TFT DT is exposed is formed through the passivation layer **515c** and the planarization layer **515d** which are located on the driving TFT DT.

[0452] That is, the first electrode **518** is provided on the planarization layer **515d**, and electrically connected to the drain electrode **523** of the driving TFT DT through the drain contact hole.

[0453] The first electrode **518** is to supply a current (or a voltage) to the organic compound layer **530**, and defines a light-emitting region with a predetermined area (or size).

[0454] The first electrode **518** serves as an anode. Accordingly, the first electrode **518** may include a transparent conductive material with a relatively great work function. Also, the first electrode **518** may be formed in a multi-layered structure including a plurality of electrode layers. For example, the first electrode **518** may be formed in a three-layered structure which is prepared by sequentially stacking a first electrode layer **518a**, a second electrode layer **518b** and third electrode layer **518c**.

[0455] The first electrode layer **518a** may increase the adhesive strength of the second electrode layer **518b**. The first electrode layer **518a** may be formed of Indium Tin Oxide (ITO) or Indium Zinc Oxide (IZO). To improve reflectivity, the second electrode layer **518b** may be a reflection layer made of a metal with high reflectivity. Examples of the metal having the high reflectivity may include aluminum (Al), silver (Ag), gold (Au), platinum (Pt), chrome (Cr) or alloy thereof.

[0456] The third electrode layer **518c** may have a high work function. As such, the first electrode **518** may be used as the anode electrode. Such a third electrode layer **518c** may be a transparent conductive layer. For example, the third electrode layer **518c** may be formed from ITO or IZO. However, the present invention may not be limited to this.

[0457] A bank **515e** is formed on the substrate **510** having the first electrode **518**. Here, the bank **515e** defines a first opening by surrounding an edge of the first electrode **518** like a bank. The bank **515e** may be made of an organic or inorganic insulating material. The bank **515e** may also be made of a photosensitive material containing black pigments. In this instance, the bank **515e** serves as a shielding member.

[0458] The bank **515e** may be formed to surround edges of the first electrode **518**. As such, any corrosion of the edges of the first electrode **518** may be prevented.

[0459] Here, in the fifth embodiment of the present invention, the bank **515e** further include a second opening through which an auxiliary electrode **525** to be explained later is partially exposed.

[0460] The organic compound layer **530** is provided between the first electrode **518** and the second electrode **528**. The organic compound layer **530** emits light as holes supplied from the first electrode **518** and electrons supplied from the second electrode **528** are coupled to each other.

[0461] Here, FIG. 10A illustrates an example that the organic compound layer **230** is formed on an entire surface of the substrate **210**. However, the present invention may not be limited to this. The organic compound layer **230** may also be formed on the first electrode **218**.

[0462] Although it is shown in FIG. 10A that the organic compound layer **530** is formed in a single layer, the organic compound layer **530** is not limited to this. The organic compound layer **530** may have a multi-layered structure including a light-emitting layer to emit light and an auxiliary layer for improving light-emission efficiency of the light-emitting layer.

[0463] The second electrode **528** is formed on the organic compound layer **530** to supply electrons to the organic compound layer **530**.

[0464] The second electrode **528** serves as a cathode. Accordingly, the second electrode **528** may be made of a transparent conductive material. An example of the transparent conductive material may include ITO or IZO. The second electrode **528** may further include a metal layer which is provided at a side contactable with the organic compound

layer **530** and is formed of a metal with a low work function. Examples of the metal with the low work function may include magnesium (Mg), silver (Ag) and a compound thereof.

[0465] As the same as the first to the fourth embodiments of the present invention, an auxiliary electrode line **VSSLa** and the first electrode **518** are provided on the same layer to reduce resistance of the second electrode **528**. Here, the auxiliary electrode line **VSSLa** includes the auxiliary electrode **525** and the barrier wall **535**.

[0466] The auxiliary electrode **525** and the first electrode **518** are formed on the same layer. The auxiliary electrode **525** is spaced apart from the first electrode **518**. For example, the auxiliary electrode **525** may extend long in one direction to be connected to an external **VSS** pad.

[0467] The auxiliary electrode **525** may be implemented into a three-layered structure of a first auxiliary electrode layer **525a**, a second auxiliary electrode layer **525b** and a third auxiliary electrode layer **525c**, as substantially the same as the structure of the first electrode **518**. In this instance, upon depositing the second electrode **528**, the second electrode **528** may come in contact directly with the third auxiliary electrode layer **525c** of the auxiliary electrode **525**. That is, the second electrode **528** is deposited even to a lower portion of the barrier wall **535** so as to come in contact with the auxiliary electrode **525**. However, the present invention may not be limited to this.

[0468] The barrier wall **535** is located on the auxiliary electrode **525**.

[0469] Here, the barrier wall **535** may have a tapering shape that its cross-section is reduced from top to bottom thereof. For example, an angle formed by a side surface of the barrier wall **535** and the auxiliary electrode **525** may be in the range of 20 to 80°. This reverse tapering shape having the angle at the side surface may derive a shading effect to be explained later.

[0470] The barrier wall **535** forms an electrode contact hole through the organic compound layer **530** so as to expose the auxiliary electrode **525** therethrough. The organic compound layer **530** is formed on a top of the barrier wall **535**, but not formed below the barrier wall **535** by the shading effect. Accordingly, the electrode contact hole is formed through the organic compound layer **530**.

[0471] The organic compound layer **530** and the second electrode **528** are sequentially stacked (laminated) on the barrier wall **535**.

[0472] The pad area is an edge area of the TFT substrate **510** having the display area. The pad area includes a gate pad area and a data pad area.

[0473] Referring to FIG. 10B, a gate pad electrode **526p** and a data pad electrode **527p** which are electrically connected to a gate line and a data line, respectively, are located on the gate pad area and the data pad area. The gate pad electrode **526p** and the data pad electrode **527p** transfer a scan signal and a data signal applied from an external driving circuit to the gate line and the data line, respectively.

[0474] That is, the gate line and the data line extend toward the driving circuit to be connected to corresponding gate pad line **516p** and data pad line **517p**, respectively. The gate pad line **516p** and the data pad line **517p** are electrically connected to the gate pad electrode **526p** and the data pad electrode **527p**, respectively. Therefore, the gate line and the data line

receive the scan signal and the data signal, respectively, from the driving circuit through the gate pad electrode **526p** and the data pad electrode **527p**.

[0475] The gate pad line **516p** and the gate line may be formed in a single body united with each other.

[0476] Moreover, the gate pad line **516p** and the data pad line **517p** may be formed through the same process as the gate line and the gate electrode **521**.

[0477] The data pad electrode **527p** and the data line may be formed in a single body united with each other.

[0478] Also, the gate pad electrode **526p** and the data pad electrode **527p** may be formed through the same process as the data line and the source and drain electrodes **522** and **523**.

[0479] Although the gate pad line **516p** and the data pad line **517p** are formed in a single layer, they may be formed in a multi-layered structure including at least two layers.

[0480] A plurality of contact holes exposing the gate pad line **516p** and the data pad line **517p** may be formed in the inter-layer insulating layer **515b** of the pad area. Also, an open hole **H** exposing the gate pad electrode **526p** and the data pad electrode **527p** may be formed in the passivation layer **515c** of the pad area.

[0481] The gate pad electrode **526p** and the data pad electrode **527p** according to the fifth embodiment of the present invention are formed on the same layer as the data wiring of the display area, here have substantially the same three-layered structure as the data wiring, for example, the three-layered structure of **MoTi/Cu/MoTi**.

[0482] That is, in the fifth embodiment of the present invention, the three-layered structure of **MoTi/Cu/MoTi** having etch selectivity with respect to an etchant for etching **Ag** or **Ag** alloy is applied to the gate pad electrode **526p** and the data pad electrode **527p** of the pad area, and also parts of the gate pad electrode **526p** and the data pad electrode **527p** are externally exposed by forming an open hole **H** during patterning of the passivation layer **515c**.

[0483] In this instance, the upper **MoTi** may serve as an etch stopper of the etchant etching **Ag** or **Ag** alloy.

[0484] As described above, in order to pattern the first electrode **518**, a phosphoric acid-based etchant, a nitric acid-based etchant, a phosphoric acid+nitric acid-based etchant, a phosphoric acid+acetic acid-based etchant, a nitric acid+acetic acid-based etchant, or a phosphoric acid+nitric acid+acetic acid-based etchant may be used. Also, in order to pattern the first electrode **518**, an etchant that does not contain hydrofluoric acid potassium and hydrogen peroxide may be used.

[0485] The gate pad electrode **526p** according to the fifth embodiment of the present invention may have the three-layered structure of a first gate pad electrode layer **526pa**, a second gate pad electrode layer **526pb** and a third gate pad electrode layer **526pc**, and the data pad electrode **527p** may have the three-layered structure of a first data pad electrode layer **527pa**, a second data pad electrode layer **527pb** and a third data pad electrode layer **527pc**.

[0486] The lowermost layers, i.e. the first gate pad electrode layer **526pa** and the first data pad electrode layer **527pa** may be an adhesion promoting layer increasing the adhesive strength of the second gate pad electrode layer **526pb** and the second data pad electrode layer **527pb**. That is, the first gate pad electrode layer **526pa** may be made of a material configured so as to increase the adhesion between the second gate pad electrode layer **526pb** and a fourth pad electrode layer, i.e. the gate pad line **516p**. Also, the first data pad electrode layer

**527pa** may be made of a material configured so as to increase the adhesion between the second data pad electrode layer **527pb** and the data pad line **517p**.

[0487] The second gate pad electrode layer **526pb** and the second data pad electrode layer **527pb** may be formed from a low resistive material compared with the first gate pad electrode layer **526pa**, the first data pad electrode layer **527pc** and the third gate pad electrode layer **526pc**, the third data pad electrode layer **527pc**.

[0488] The pad electrodes **526p** and **527p** must be externally exposed for the connection with an external driver later. The pad electrodes **526p** and **527p** formed from copper Cu or others can be easy to transfer signals because of their low resistance. Meanwhile, the exposed pad electrodes **526p** and **527p** may be corroded by external moisture and oxygen. Moreover, the pad electrodes **526p** and **527p** formed from copper Cu or others can be etched at the formation of the first electrode **518** which is performed for the formation of the OLED later.

[0489] To address this matter, the uppermost third pad electrode layers **526pc** and **527pc** may be formed from a material which is not corroded by oxygen and moisture, even though they are externally exposed. In other words, the third pad electrode layers **526pc** and **527pc** may be formed from a material being not etched by an etchant which may be used to form the first electrode **518**. For example, the third pad electrode layers **526pc** and **527pc** may be formed from one of molybdenum titanium MoTi, titanium Ti or an alloy thereof.

[0490] Also, the passivation layer **515c** may be formed in such a manner as to expose upper surfaces of the third pad electrode layers **526pc** and **527pc** of the pad electrodes **526p** and **527p**. In other words, the passivation layer **515c** may be formed in such a manner as to surround edges of the upper surfaces of the pad electrodes **526p** and **527p**. As such, any corrosion of the sides of the third pad electrode layers **526pc** and **527pc** may be prevented. For example, the passivation layer **515c** may be formed in such a manner as to cover sides of the third pad electrode layers **526pc** and **527pc**, and at least some portions of the upper surfaces of the third pad electrode layers **526pc** and **527pc**.

[0491] Here, when the etchant for etching Ag or Ag alloy permeates into a crack generated due to impurity or a crack which is generated during patterning of the passivation layer **515c**, it may damage Cu of the gate pad electrode **526p** and the data pad electrode **527p**. To prevent the damage, the fifth embodiment of the present invention employs a clad structure in which the third gate pad electrode layer **526pc** and the third data pad electrode layer **527pc** cover the first and second gate pad electrode layers **526pb** and **526pa** and the first and second data pad electrode layers **527pb** and **527pa**.

[0492] Such structure provides several effects of improvement of reliability, reduction of defects and improvement of productivity.

[0493] To form the clad structure, for example, after patterning the first and second gate pad electrode layers **526pb** and **526pa** and the first and second data pad electrode layers **527pb** and **527pa**, followed by patterning the third gate pad electrode layer **526pc** and the third data pad electrode layer **527pc** thereon. In this instance, the third gate pad electrode layer **526pc** and the third data pad electrode layer **527pc** may have more increased widths than the first and second gate pad electrode layers **526pb** and **526pa** and the first and second data pad electrode layers **527pb** and **527pa**.

[0494] That is, the third gate pad electrode layer **526pc** and the third data pad electrode layer **527pc** may be configured so as to be in contact with both sides of the first gate pad electrode layer **526pa** and the first data pad electrode layer **527pa**, respectively, then so as to seal the second gate pad electrode layer **526pb** and the second data pad electrode layer **527pb**.

[0495] For reference, when the gate pad electrode **526p** and the data pad electrode **527c** according to the fifth embodiment of the present invention may be patterned to the three-layered structure of MoTi/Cu/MoTi as the aforementioned second embodiment, Cu may be etched faster than MoTi according to the different etching speed between the Cu and MoTi for the patterning of MoTi/Cu/MoTi through a photolithography process.

[0496] Thus, an overhang structure having extruded MoTi layer as eaves may be formed. Because of the overhang structure, the crack may be formed during the forming of the gate pad electrode **226p** and the data pad electrode **227p**. Therefore, when the etchant for etching Ag or Ag alloy permeates in the crack, the gate pad electrode **226p** and the data pad electrode **227p** may be damaged.

[0497] Therefore, in the fifth embodiment of the present invention, the formation of the overhang structure can be prevented by using the clad structure of covering the upper MoTi after first patterning Cu/MoTi.

[0498] Hereinafter, a method of fabricating an OLED display device according to the fifth embodiment of the present invention having the configuration will be described in detail with reference to the accompanying drawings.

[0499] FIGS. 11A to 11J are sectional views sequentially illustrating a method of fabricating the OLED display device according to the fifth embodiment illustrated in FIG. 10A, which sequentially illustrates a method of fabricating a TFT substrate of a display area.

[0500] And, FIGS. 12A to 12F are sectional views sequentially illustrating a method of fabricating the OLED display device according to the fifth embodiment illustrated in FIG. 10B, which sequentially illustrates a method of fabricating a TFT substrate of a pad area.

[0501] As illustrated in FIGS. 11A and 12A, a substrate **510** which is made of an insulating material, such as a transparent glass material, transparent plastic with high flexibility, a polymer film or the like is provided.

[0502] Although not illustrated, a TFT and a storage capacitor are formed on each of red, green and blue sub pixels of the substrate **510**.

[0503] First, a buffer layer is formed on the substrate **510**.

[0504] Here, the buffer layer may be formed to protect the TFT from impurities such as alkaline ion discharged from the substrate **510** during crystallization of a semiconductor layer. The buffer layer may be made of silicon dioxide.

[0505] Next, a semiconductor thin film is formed on the substrate **510** having the buffer layer.

[0506] The semiconductor thin film may be made of amorphous silicon, polycrystalline silicon, or oxide semiconductor.

[0507] Here, the polycrystalline silicon may be generated by employing various crystallization methods after depositing amorphous silicon on the substrate **210**. When the oxide semiconductor is used as the semiconductor thin film, the oxide semiconductor may be deposited, followed by a predetermined thermal treatment therefor.

[0508] Afterwards, the semiconductor thin film is selectively removed through a photolithography process to form a

semiconductor layer **524**, which is formed of the semiconductor thin film, on the substrate **510** of the display area.

[0509] As illustrated in FIGS. **11B** and **12B**, a gate insulating layer **515a** and a first conductive layer are formed on the substrate **510** having the semiconductor layer **524**.

[0510] The gate insulating layer **515a** may be formed on the entire surface of the substrate **510** provided with the semiconductor layer **524**.

[0511] The first conductive layer may be provided to form a gate line, and made of a low-resistant opaque conductive material, such as aluminum (Al), copper (Cu), molybdenum (Mo), chrome (Cr), gold (Au), titanium (Ti), nickel (Ni), neodymium (Nd) or alloy thereof. However, these materials may have a multi-layered structure including two conductive layers which exhibit different physical properties. One of the conductive layers may be made of a metal with low resistivity, for example, aluminum-based metal, silver-based metal, copper-based metal or the like, so as to reduce a signal delay or a voltage drop.

[0512] Afterwards, the first conductive layer is selectively removed through the photolithography process. Accordingly, a gate line including a gate electrode **521**, which is made of the first conductive layer, and a lower sustaining electrode **509** are formed on the substrate **510** of the display area, and also a gate pad line **516p** and a data pad line **517p**, which are formed of the first conductive layer, are formed on the substrate **510** on a pad area.

[0513] The gate electrode **521** may be formed in such a manner as to overlap with the semiconductor layer **524** within the display area.

[0514] The gate pad line **516p** and the gate line may be formed in a single body united with each other.

[0515] Although the gate electrode **521**, the gate line, the lower sustaining electrode **509** and the gate pad line **516p** are formed in a single layer, they may be formed in a multi-layered structure including at least two layers.

[0516] However, the present invention may not be limited to this. The gate line including the semiconductor layer **524** and the gate electrode **521**, the lower sustaining electrode **509**, the gate pad line **516p** and the data pad line **517p** may be simultaneously formed through one photolithography process.

[0517] Also, the lower gate insulating layer **515a** may also be patterned together during patterning of the gate line having the gate electrode **521**, the lower sustaining electrode **509**, the gate pad line **516p** and the data pad line **517p**.

[0518] Next, as illustrated in FIGS. **11C** and **12C**, an inter-layer insulating layer **515b**, which is made of silicon nitride or silicon dioxide is formed on the entire surface of the substrate **510** having the gate line having the gate electrode **521**, the lower sustaining electrode **509**, the gate pad line **516p** and the data pad line **517p**.

[0519] The inter-layer insulating layer **515b** may be formed on entire surface of the substrate **510**.

[0520] The inter-layer insulating layer **515b** and the gate insulating layer **515a** are selectively patterned through the photolithography. Accordingly, a first contact hole **550a** is formed such that a source/drain area of the semiconductor layer **524** is exposed therethrough, and also a second contact hole **550b** and a third contact hole **550c** are formed, respectively, such that parts of the gate pad line **516p** and the data pad line **517p** are exposed therethrough.

[0521] As illustrated in FIGS. **11D** and **12D**, after forming a second conductive layer and a third conductive layer on the

entire surface of the substrate **510** having the inter-layer insulating layer **515b**, the second and third conductive layers are selectively removed through the photolithography process, thereby forming on the substrate **510** of the display area a primary data wiring (namely, first and second source and drain electrode layers **522b**, **522a**, **523b** and **523a**, first and second driving voltage line layers, first and second data line layers and first and second upper sustaining electrode layers **519b** and **519a**), which is made of the second and third conductive layers.

[0522] Simultaneously, on the substrate **510** of the pad area is formed a primary pad electrode (namely, first and second gate pad electrode layers **526pb** and **526pa** and first and second data pad electrode layers **527pb** and **527pa**), which is made of the second and third conductive layers.

[0523] Here, the third conductive layer is made of a low-resistant opaque conductive material, such as aluminum (Al), copper (Cu), molybdenum (Mo), chrome (Cr), gold (Au), titanium (Ti), nickel (Ni), neodymium (Nd), or alloy thereof, in order to form the middle data line and pad electrode. However, these may have a multi-layered structure including two conductive layers which exhibit different physical properties. Specifically, in the third embodiment of the present invention, the third conductive layer is made of Cu which may be etched with respect to an etchant for etching Ag or Ag alloy.

[0524] Also, the second conductive layer may be made of MoTi in order to form the lower data line and the lower pad electrode. However, the present invention may not be limited to this. The second conductive layer may also be made of any other material if it can increase a contact characteristic with a lower layer. For example, the second conductive layer may be formed from one of molybdenum titanium MoTi, titanium Ti or an alloy thereof.

[0525] As illustrated in FIGS. **11E** and **12E**, after forming a fourth conductive layer on the entire surface of the substrate **510** having the primary data wiring, the fourth conductive layer is selectively removed through the photolithography, thereby forming on the substrate **510** of the display area a secondary data wiring (namely, third source and drain electrode layers **522c** and **523c**, a third driving voltage line layer, a third data line layer and a third upper sustaining electrode layer **519c**), which is made of the fourth conductive layer.

[0526] Simultaneously, on the substrate **510** of the pad area is formed a secondary pad electrode (namely, a third gate pad electrode layer **526pc** and a third data pad electrode layer **527pc**), which is made of the fourth conductive layer.

[0527] Here, the fourth conductive layer may be made of MoTi in order to form the third data wiring and pad electrode. However, the present invention may not be limited to this. The fourth conductive layer may also be made of any other material if it can be used as an etch stopper of an etchant for etching Ag or Ag alloy.

[0528] In this manner, through the twice patterning, a source electrode **522** which has a three-layered structure of the first source electrode layer **522a**, the second source electrode layer **522b** and the third source electrode layer **522c**, and a drain electrode **523** which has a three-layered structure of the first drain electrode layer **523a**, the second drain electrode layer **523b** and the third drain electrode layer **523c** may be formed on the substrate **510** of the display area.

[0529] Also, an upper sustaining electrode **519**, which has a three-layered structure of the first upper sustaining electrode layer **519a**, the second upper sustaining electrode layer

**519b** and the third upper sustaining electrode layer **519c** may be formed on the lower sustaining electrode **509**.

**[0530]** Simultaneously, a gate pad electrode **526p** which has a three-layered structure of the first gate pad electrode layer **526pa**, the second gate pad electrode layer **526pb** and the third gate pad electrode layer **526pc**, and a data pad electrode **527p** which has a three-layered structure of the first data pad electrode layer **527pa**, the second data pad electrode layer **527pb** and the third data pad electrode layer **527pc** may be formed on the substrate **510** of the pad area.

**[0531]** Here, as aforementioned, the data wiring and the pad electrode according to the fifth embodiment of the present invention may have the three-layered structure of MoTi/Cu/MoTi.

**[0532]** Meanwhile, the fifth embodiment of the present invention may employ a clad structure that the secondary pad electrode, namely, the third gate pad electrode layer **526pc** and the third data pad electrode layer **527pc**, covers the primary pad electrode, namely, the first and second gate pad electrode layers **526pb** and **526pa** and the first and second data pad electrode layers **527pb** and **527pa**. This structure can prevent in advance the etchant for etching Ag or Ag alloy from damaging the Cu of the gate pad electrode **526p** and the data pad electrode **527p** due to permeating into a crack generated by impurities or a crack generated during patterning of a passivation layer.

**[0533]** The third gate pad electrode layer **526pc** and the third data pad electrode layer **527pc** may be configured so as to be in contact with both sides of the first gate pad electrode layer **526pa** and the first data pad electrode layer **527pa**, respectively, then so as to seal the second gate pad electrode layer **526pb** and the second data pad electrode layer **527pb**.

**[0534]** Here, the source and drain electrodes **522** and **523** are electrically connected to the source/drain area of the semiconductor layer **524** through the first contact hole. The upper sustaining electrode **519** overlaps a part of the lower sustaining electrode **509** with interposing the inter-layer insulating layer **515b** therebetween, thereby forming a storage capacitor.

**[0535]** The gate pad electrode **526p** and the data pad electrode **527p** are electrically connected to the gate pad line **516p** and data pad line **517p** through the second and third contact holes, respectively.

**[0536]** Afterwards, as illustrated in FIGS. 11F and 12F, a passivation layer **515c** which is made of silicon nitride or silicon dioxide is formed on the substrate **510** of the display area on which the source and drain electrodes **522** and **523**, the driving voltage line, the data line, the upper sustaining electrode **519**, the gate pad electrode **526p** and the data pad electrode **527p** are formed.

**[0537]** Here, a planarization layer **515d** made of an organic insulating material may be formed on the passivation layer **515c**, but the present invention may not be limited to this. The passivation layer may also function as the planarization layer.

**[0538]** The passivation layer **515c** and the planarization layer **515d** are selectively patterned through the photolithography process, thereby forming a fourth contact hole **550d** through which the drain electrode **523** is exposed, and an open hole H through which parts of the gate pad electrode **526p** and the data pad electrode **527p** are externally exposed.

**[0539]** Next, as illustrated in FIG. 11G, fifth to seventh conductive layers are formed on the entire surface of the substrate **510** having the planarization layer **515d**.

**[0540]** However, the present invention may not be limited to this. For example, only the fifth conductive layer may also be formed as a single layer on the entire surface of the substrate **510** having the planarization layer **515d**.

**[0541]** The fifth conductive layer and the seventh conductive layer may be made of a transparent conductive material, such as ITO or IZO.

**[0542]** The sixth conductive layer may be made of aluminum (Al), silver (Ag), gold (Au), platinum (Pt), chrome (Cr) or alloy thereof.

**[0543]** Afterwards, by selectively patterning the fifth to seventh conductive layers through the photolithography process, a first electrode **518** and an auxiliary electrode **525** made of the fifth to seventh conductive layers are formed.

**[0544]** Here, the first electrode **518** may include a first electrode layer **518a**, a second electrode layer **518b** and a third electrode layer **518c** which are made of the fifth to seventh conductive layers, respectively.

**[0545]** The auxiliary electrode **525** may include a first auxiliary electrode layer **525a**, a second auxiliary electrode layer **525b** and a third auxiliary electrode layer **525c** which are made of the fifth to seventh conductive layers, respectively.

**[0546]** The first electrode **518** as an anode may be electrically connected to the drain electrode **523** of the driving TFT through the fourth contact hole.

**[0547]** Also, the first electrode **518** is formed on the substrate **510** to correspond to each of red, green and blue sub pixels.

**[0548]** Next, as illustrated in FIG. 11H, a predetermined bank **515e** is formed on the substrate **510** of the display area having the first electrode **518** and the auxiliary electrode **525**.

**[0549]** Here, the bank **515e** defines an opening by surrounding an edge region of the first electrode **518** like a bank and is made of an organic or inorganic insulating material. The bank **515e** may also be made of a photosensitive material containing black pigments, and in this instance, the bank **515e** may serve as a shielding member.

**[0550]** Also, the bank **515e** further includes a second opening through which the auxiliary electrode **525** is partially exposed.

**[0551]** As illustrated in FIG. 11I, a barrier wall **535** is formed on the substrate **510** having the bank **515e**.

**[0552]** The barrier wall **535** is located on the auxiliary electrode **525**.

**[0553]** Here, the barrier wall **535** may have a reverse tapering shape that its section is reduced from top to bottom thereof. For example, an angle formed by a side surface of the barrier wall **535** and the auxiliary electrode **525** may be in the range of 20 to 80°. This reverse tapering shape having the angle at the side surface may derive a shading effect to be explained later.

**[0554]** Next, as illustrated in FIG. 11J, an organic compound layer **530** is formed on the substrate **510** having the barrier wall **535** by way of evaporation.

**[0555]** In this instance, the barrier wall **535** forms an electrode contact hole, through which the auxiliary electrode **525** is exposed, on the organic compound layer **530**. The organic compound layer **530** is formed on the top the barrier wall **535**, and not formed below the top of the barrier wall **535** by the shading effect. Accordingly, the electrode contact hole is formed through the organic contact hole **530**.

**[0556]** To this end, although not illustrated, a hole injection layer and a hole transport layer are sequentially formed on the substrate **510**.

[0557] Here, the hole injection layer and the hole transport layer are commonly formed on each of the red, green and blue sub pixels, so as to allow for smooth injection and transport of the holes. Here, one of the hole injection layer and the hole transport layer may be omitted.

[0558] Next, a light-emitting layer is formed on the substrate 510 having the hole transport layer.

[0559] The light-emitting layer may include a red light-emitting layer, a green light-emitting layer and a blue-light emitting layer to correspond to the red, green and blue sub pixels.

[0560] An electron transport layer is then formed on the substrate 510 having the light-emitting layer.

[0561] The electron transport layer is commonly formed on each of the red, green and blue sub pixels on the light-emitting layer, so as to allow for smooth transport of the electrons.

[0562] An electron injection layer for smooth injection of the electrons may further be formed on the electron transport layer.

[0563] A second electrode 528 made of an eighth conductive layer is formed on the substrate 510 having the electron transport layer in a sputtering manner.

[0564] Here, the eighth conductive layer is deposited even to a lower portion of the barrier wall 535 such that the second electrode 528 can come in contact with the auxiliary electrode 525.

[0565] The thusly-fabricated OLED is encapsulated by a predetermined thin film encapsulation layer.

[0566] A polarization film for reducing reflection of external light of the OLED display device so as to improve a contrast ratio may be provided on the thin film encapsulation layer.

[0567] As aforementioned, an OLED display device and a method of fabricating the same according to one embodiment of the present invention can improve luminance uniformity of a panel by reducing resistance of a cathode in a manner of forming an auxiliary electrode.

[0568] Also, a pad electrode may be formed of a plurality of pad electrode layers and an uppermost layer of the pad electrode layers may be formed a material capable of preventing (or minimizing) a corrosion from moisture and oxygen, to prevent (or minimize) the corrosion of the pad electrode and an occurrence of migration. This may result in preventing (or minimizing) a defect of the transmission of signals.

[0569] Moreover, a clad structure (or other protective configuration) may be applied to a pad electrode of a pad area and a low-resistance pad electrode layer may be sealed by the clad structure, to prevent (or minimize) corrosion due to moisture and oxygen and prevent (or minimize) damage on the pad electrode due to an etchant during patterning of an anode. This may result in improvement in device reliability, reduction of defectives in the OLED display device, and improvement in manufacturing productivity.

[0570] Moreover, an OLED display device and a method of fabricating the same according to one embodiment of the present invention can reduce production costs by simplifying the process required to form a plurality of the pad electrode layers.

[0571] It will be apparent to those skilled in the art that various modifications and variations can be made in the organic light-emitting diode display device and method of fabricating the same of the present invention without departing from the spirit or scope of the invention. Thus, it is intended that the present invention cover the modifications

and variations of this invention provided they come within the scope of the appended claims and their equivalents.

What is claimed is:

1. An organic light-emitting diode (OLED) display device, comprising:

a thin film transistor on a display area of a substrate;  
an OLED connected to the thin film transistor; and  
a plurality of pad electrodes comprising at least a first pad electrode layer, a second pad electrode layer and a third pad electrode layer on a pad area of the substrate, wherein the first pad electrode layer below the second pad electrode layer is an adhesion promoting layer, wherein the second pad electrode layer is formed of a low resistive material compared with materials of the first and third pad electrode layers, and wherein the third pad electrode layer above the second pad electrode layer serves the purpose of an etch stopper for the second pad electrode layer.

2. The display device of claim 1, wherein the second pad electrode layer includes Cu, and the first pad electrode layer includes MoTi, Ti or its alloy.

3. The display device of claim 2, wherein a material of the first pad electrode layer is the same as that of the third pad electrode layer.

4. The display device of claim 2, further comprising:  
a passivation layer covering sides of the first, second and third pad electrode layers, and at least some portions of an upper surface of the third pad electrode layer.

5. The display device of claim 2, wherein the third pad electrode layer is in contact with both sides of the first pad electrode layer to seal the second pad electrode layer.

6. The display device of claim 1, further comprising:  
a first electrode, an organic compound layer and a second electrode,  
wherein the second pad electrode layer is formed of a material that is etched by an etchant which is used to pattern the first electrode, and  
wherein the third pad electrode layer is formed of a material that is not etched by the etchant.

7. The display device of claim 1, wherein the first electrode includes at least one among Ag, Al, Ag alloy and Al alloy.

8. The display device of claim 7, wherein the plurality of pad electrodes are not of the same material as the first electrode.

9. The display device of claim 6, wherein the etchant includes at least one among a phosphoric acid, a nitric acid and an acetic acid, but does not include hydrofluoric acid potassium and hydrogen peroxide.

10. The display device of claim 1, further comprising:  
a fourth pad electrode layer below the first pad electrode layer, and being contact with the first pad electrode layer.

11. The display device of claim 10, wherein the adhesion promoting layer is formed of a material that increases the adhesion between the second pad electrode layer and the fourth pad electrode layer.

12. The display device of claim 11, further comprising:  
an inter-layer insulating layer located between the first pad electrode layer and the fourth pad electrode layer, to cover some portion of an upper surface of fourth pad electrode layer.

13. An organic light-emitting diode (OLED) display device, comprising:  
a substrate including a display area and a pad area;  
a pad line and a pad electrode in the pad area; and

- a patterned anode, configured by etching, in the display area,  
 wherein the pad electrode is a three-layered structure,  
 wherein an uppermost layer and a lowermost layer of the three-layered structure are of the same material, and  
 wherein the uppermost layer is not etched by an etchant which is used to pattern the anode, and is formed of a material to prevent corrosion of an intermediate layer of the three-layered structure.
- 14.** The display device of claim **13**, wherein the uppermost layer is in contact with both sides of the lowermost layer to seal the lowermost layer.
- 15.** The display device of claim **14**, wherein the intermediate layer includes Cu, and the uppermost layer includes MoTi, Ti or its alloy.
- 16.** The display device of claim **13**, wherein the display area further includes a data wiring, and  
 wherein the uppermost layer and the lowermost layer are on the same layer as the data wiring.
- 17.** The display device of claim **13**, wherein the anode includes at least one among Ag, Al, Ag alloy and Al alloy.
- 18.** A method of fabricating an organic light-emitting diode (OLED) display device, the method comprising:
- forming a thin film transistor on a display area of a substrate;  
 forming a pad electrode having a three-layered structure on a pad area of the substrate;  
 forming an open hole exposing a portion of an uppermost layer of the pad electrode by selectively etching a passivation layer on the pad area; and  
 patterning an anode on the passivation layer over the thin film transistor by etching,  
 wherein the uppermost layer exposed via the open hole is not etched during the patterning of the anode.
- 19.** The method of claim **18**, wherein an intermediate layer of the pad electrode includes Cu,  
 wherein the uppermost layer and a lowermost layer of the pad electrode include MoTi, Ti or its alloy, and  
 wherein an etchant used for patterning the anode includes at least one among a phosphoric acid, a nitric acid and an acetic acid, but does not include hydrofluoric acid potassium and hydrogen peroxide.
- 20.** The method of claim **19**, wherein the uppermost layer is in contact with both sides of the lowermost layer to seal the intermediate layer.

\* \* \* \* \*

专利名称(译)	有机发光二极管显示装置及其制造方法		
公开(公告)号	<a href="#">US20160013436A1</a>	公开(公告)日	2016-01-14
申请号	US14/796090	申请日	2015-07-10
[标]申请(专利权)人(译)	乐金显示有限公司		
申请(专利权)人(译)	LG DISPLAY CO. , LTD.		
当前申请(专利权)人(译)	LG DISPLAY CO. , LTD.		
[标]发明人	IM JONGHYEOK KIM SEJUNE LEE JOONSUK LEE SOJUNG LEE JAESUNG		
发明人	IM, JONGHYEOK KIM, SEJUNE LEE, JOONSUK LEE, SOJUNG LEE, JAESUNG		
IPC分类号	H01L51/52 H01L27/32 H01L51/00 H01L51/56		
CPC分类号	H01L51/5203 H01L27/3276 H01L51/0017 H01L51/5206 H01L51/56 H01L51/5237 H01L51/5218 H01L51/5228 H01L2251/5315		
优先权	1020140087751 2014-07-11 KR 1020150097544 2015-07-09 KR 1020140087665 2014-07-11 KR		
其他公开文献	US10181573		
外部链接	<a href="#">Espacenet</a> <a href="#">USPTO</a>		

摘要(译)

有机发光二极管 ( OLED ) 显示装置及其制造方法可通过形成辅助电极来降低阴极的电阻。此外，这种OLED显示装置和方法可以通过将保护结构施加到焊盘区域的焊盘电极并且通过包括从多个焊盘电极暴露的焊盘电极来防止在阳极图案化期间由于蚀刻剂而对焊盘电极的损坏层。

